

NEET (UG) 2026

QUESTION PAPER & SOLUTION

Time : 3 Hrs

M.M.: 720

Important Instructions:

1. The test is of **3 hours** duration and the Test Booklet contains **180** multiple choice questions (Four options with a single correct answer) from **Physics, Chemistry and Biology (Botany and Zoology)**.
2. Each question carries **4 marks**. For each correct response, the candidate will get **4 marks**. For every wrong response, **1 mark** shall be deducted from the total scores. The maximum marks are **720**.
3. Use **Blue / Black Ball Point Pen only** for writing particulars on this page / marking responses on Answer Sheet.
4. Rough work is to be done in the space provided for this purpose in the Test Booklet only.
5. On completion of the test, the candidate must handover the Answer Sheet to the Invigilator before leaving the Room / Hall. The candidates are allowed to take away this Test Booklet with them.
6. The CODE for this Booklet is **11**.
7. The candidates should ensure that the Answer Sheet is not folded. Do not make any stray marks on the Answer Sheet. Do not write your Roll No. anywhere else except in the specified space in the Test Booklet/Answer Sheet. Use of white fluid for correction is **NOT** permissible on the Answer Sheet.
8. Each candidate must show on demand his/her Admission Card to the Invigilator.
9. No candidate, without special permission of the Centre Superintendent or Invigilator, would leave his/her seat.
10. Use of Electronic/Manual Calculator is prohibited.
11. The candidates are governed by all Rules and Regulations of the examination with regard to their conduct in the Examination Hall. All cases of unfair means will be dealt with as per Rules and Regulations of this examination.
12. No part of the **Test Booklet** and **Answer Sheet** shall be detached under any circumstances.
13. The candidates will write the Correct Test Booklet Code as given in the Test Booklet / Answer Sheet in the Attendance Sheet.

PHYSICS

1. The speed of light in vacuum is taken as unity. If light takes 6 min 40 s to reach the Earth from the Sun, the distance between the Sun and the Earth in new unit is:

- (1) 3×10^8 (2) 500
 (3) 3×10^{10} (4) 400

Answer (4)

Sol. Time, $t = 6 \text{ min } 40 \text{ s}$

$$= 360 + 40$$

$$= 400 \text{ s}$$

Distance in new system $d = vt$

$$= 1 \times 400 = 400$$

2. Match List I with List II:

	List I		List II
A.	Young's Modulus	I.	$\frac{\Delta d}{\Delta L} \left(\frac{L}{d} \right)$
B.	Compressibility	II.	$\frac{FL}{A(\Delta L)}$
C.	Bulk Modulus	III.	$-\frac{1}{\Delta P} \left(\frac{\Delta V}{V} \right)$
D.	Poisson's Ratio	IV.	$-P \left(\frac{V}{\Delta V} \right)$

Choose the **correct** answer from the options given below:

- (1) A-IV, B-I, C-II, D-III
 (2) A-III, B-II, C-I, D-IV
 (3) A-I, B-IV, C-III, D-II
 (4) A-II, B-III, C-IV, D-I

Answer (4)

Sol. A. Young's Modulus = $\frac{\text{Stress}}{\text{Strain}} = \frac{FL}{A\Delta L}$

B. Compressibility = $\frac{1}{\text{Bulk modulus}} = -\frac{1}{\Delta P} \left(\frac{\Delta V}{V} \right)$

C. Bulk Modulus = $-P \left(\frac{V}{\Delta V} \right)$

D. Poisson's Ratio = $\frac{\text{Lateral strain}}{\text{Longitudinal strain}} = \frac{\Delta d}{\Delta L} \left(\frac{L}{d} \right)$

3. The current I in the circuit shown below is:
(All diodes are ideal and identical)

(1) $\frac{5}{3}$ A

(2) $\frac{5}{9}$ A

(3) $\frac{1}{3}$ A

(4) $\frac{15}{2}$ A

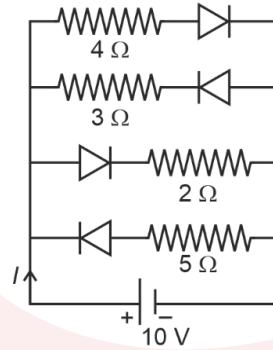

Answer (4)

Sol. For ideal diode, forward resistance = 0 and reverse biased resistance = ∞

\therefore Circuit can be redrawn as,

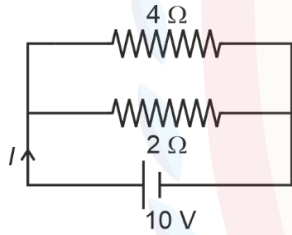

$$I = \frac{10}{2} + \frac{10}{4}$$

$$= \frac{30}{4} = \frac{15}{2} \text{ A}$$

4. The angular speed of a flywheel is increased from 600 rpm to 1200 rpm in 10 s. The number of revolutions completed by the flywheel during this time is:

(1) 900

(2) 600

(3) 150

(4) 300

Answer (3)

Sol. $\alpha = \frac{\omega_2 - \omega_1}{\Delta t} = \left(\frac{1200 - 600}{10} \right) \frac{2\pi}{60} = 2\pi \text{ rad/s}^2$

\Rightarrow Use equation of motion, $\omega_2^2 = \omega_1^2 + 2\alpha\theta$

$\Rightarrow \omega_2 = 1200 \times \frac{2\pi}{60} = 40\pi$

$\omega_1 = 600 \times \frac{2\pi}{60} = 20\pi$

$(40\pi)^2 = (20\pi)^2 + 2 \times 2\pi\theta$

$\Rightarrow 1200\pi^2 = 4\pi\theta$

$\Rightarrow \theta = 300\pi \text{ radian}$

\Rightarrow Number of revolution = $\frac{\theta}{2\pi} = 150$

5. For a simple pendulum, having time period T , the variation of kinetic energy (K.E.) with time (t) is represented by:

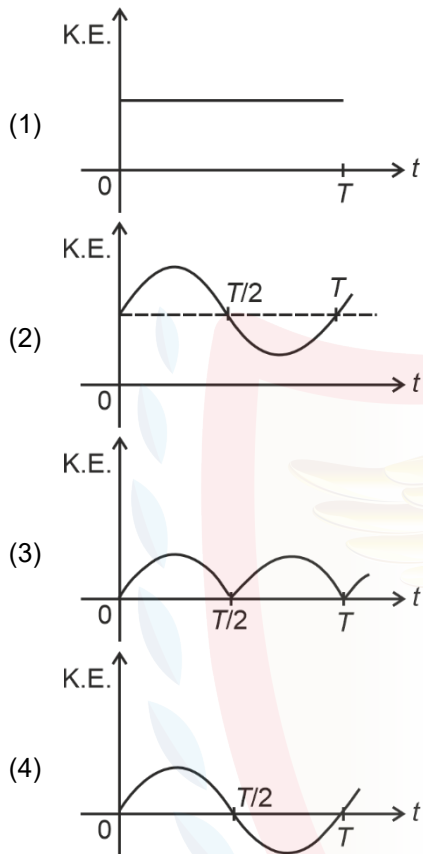

Answer (3)

Sol. Kinetic energy, $K = \frac{1}{2}mv^2$

$$= \frac{1}{2}mA^2\omega^2 \cos^2(\omega t + \phi)$$

$$\therefore K \propto \cos^2(\omega t + \phi)$$

6. A resistor is connected to a battery of 12 V emf and internal resistance 2Ω . If the current in the circuit is 0.6 A, the terminal voltage of the battery is:

- (1) 10 V (2) 1.2 V
(3) 12 V (4) 10.8 V

Answer (4)

Sol. Circuit can be draw as,

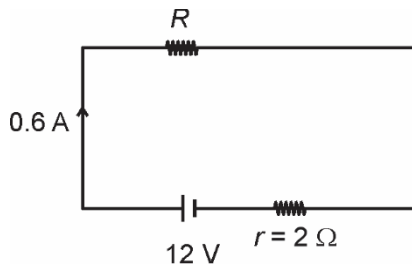

$$\Rightarrow \text{Terminal voltage of battery } V = E - ir$$

$$= 12 - 0.6 \times 2 = 10.8 \text{ V}$$

7. A flask contains argon and chlorine in the ratio of 2 : 1 by mass. The temperature of the mixture is 27°C. The ratio of root mean square speed of the molecules of the two gases $\left(\frac{V_{\text{rms}}^{\text{Ar}}}{V_{\text{rms}}^{\text{Cl}}}\right)$ is:

(Atomic mass of argon = 40.0 u and molecular mass of chlorine = 70.0 u)

- (1) $\frac{\sqrt{7}}{2}$ (2) $\frac{7}{4}$
 (3) $\frac{7}{2}$ (4) $\frac{2}{\sqrt{7}}$

Answer (1)

Sol. $v_{\text{rms}} = \sqrt{\frac{3RT}{M}}$

For same temperature, $v_{\text{rms}} \propto \frac{1}{\sqrt{M}}$

$$\frac{V_{\text{rms}}^{\text{Ar}}}{V_{\text{rms}}^{\text{Cl}}} = \sqrt{\frac{M_{\text{Cl}}}{M_{\text{Ar}}}} = \sqrt{\frac{70}{40}} = \frac{\sqrt{7}}{2}$$

8. A ray of monochromatic light is passing through an equilateral prism (ABC) as shown in the figure. The refracted ray (QR) is parallel to its base (BC) and the angle of incidence (i) is 50°. Then the angle of deviation (δ) is:

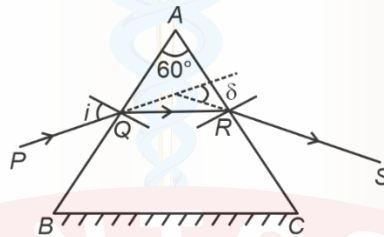

- (1) 45° (2) 35°
 (3) 40° (4) 55°

Answer (3)

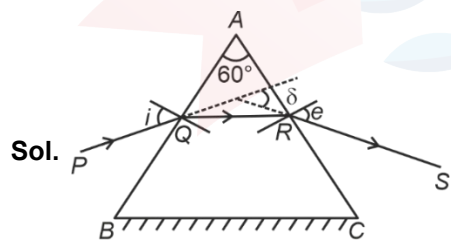

$$i = e$$

Equation of prism

$$i + e = A + \delta$$

$$2i - A = \delta$$

$$2(50) - 60 = \delta$$

$$\delta = 40^\circ$$

9. Match List I with List II.

	List-I		List-II
A.	$E = h\nu$	I.	de Broglie wavelength
B.	Diffraction and Interference	II.	Particle nature of light
C.	$\lambda = h/p$	III.	Wave nature of light
D.	Compton effect	IV.	Energy of photon

Choose the **correct** answer from the options given below.

- (1) A-IV, B-I, C-II, D-III
 (2) A-IV, B-III, C-II, D-I
 (3) A-I, B-IV, C-III, D-II
 (4) A-IV, B-III, C-I, D-II

Answer (4)

Sol. A. $E = h\nu$ is energy of photon

B. Diffraction and interference confirm wave nature of light

C. $\lambda = \frac{h}{p}$ is de Broglie wavelength of particle.

D. Compton effect confirms particle nature of light.

10. In the first excited state of hydrogen atom, the energy of its electron is -3.4 eV. The radial distance of the electron from the hydrogen nucleus in this case is approximately:

(Take $1 \text{ eV} = 1.6 \times 10^{-19} \text{ J}$, $e = 1.6 \times 10^{-19} \text{ C}$ and $\frac{1}{4\pi\epsilon_0} = 9 \times 10^9 \text{ N m}^2/\text{C}^2$)

- (1) $2.1 \times 10^{-9} \text{ m}$
 (2) $2.1 \times 10^{-8} \text{ m}$
 (3) $2.1 \times 10^{-10} \text{ m}$
 (4) $2.1 \times 10^{-11} \text{ m}$

Answer (3)

Sol. $\frac{KQ^2}{2r} = 3.4 \text{ eV}$

$$\frac{9 \times 10^9 \times (1.6 \times 10^{-19})^2}{2 \times 3.4 \times 1.6 \times 10^{-19}} = r$$

$$2.1176 \times 10^{-10} = r$$

$$r = 2.1 \times 10^{-10} \text{ m}$$

11. A box of mass 15 kg is kept on the floor of a stationary trolley. The coefficient of static friction between the box and the trolley is 0.12 . Keeping the box in stationary state over the trolley, the maximum acceleration with which the trolley can be moved horizontally in m s^{-2} is:

($g = 10 \text{ m/s}^2$)

- (1) 2.1
 (2) 1.8
 (3) 1.5
 (4) 1.2

Answer (4)

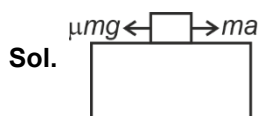

$$a = \mu g = 0.12 \times 10 = 1.2 \text{ m/s}^2$$

12. Five capacitors of capacitances

$C_1 = C_2 = C_3 = C_4 = 10 \mu\text{F}$ and $C_5 = 2.5 \mu\text{F}$ are connected as shown, along with a battery of 50 V.

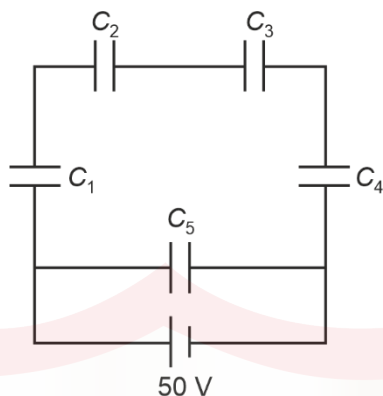

The equivalent capacitance and the charges on each capacitor respectively are:

- (1) $5 \mu\text{F}$, $125 \mu\text{C}$ on C_1 to C_4 and $25 \mu\text{C}$ on C_5
- (2) $5 \mu\text{F}$, $125 \mu\text{C}$ on all capacitors
- (3) $5 \mu\text{F}$, $250 \mu\text{C}$ on all capacitors
- (4) $4 \mu\text{F}$, $250 \mu\text{C}$ on C_1 to C_4 and $125 \mu\text{C}$ on C_5

Answer (2)

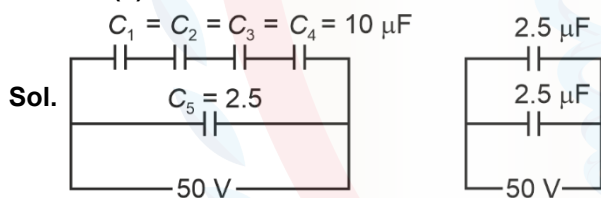

$$C_{\text{eq}} = 2.5 + 2.5 = 5 \mu\text{F}$$

$$q_1 = q_2 = q_3 = q_4 = 2.5 \times 50 = 125 \mu\text{C}$$

$$q_5 = 2.5 \times 50 = 125 \mu\text{C}$$

13. The amount of work done to raise a mass ' m ' from the surface of the Earth to a height equal to the radius of the Earth ' R ' will be

- (1) $2 mg R$
- (2) $mg \frac{R}{4}$
- (3) mgR
- (4) $mg \frac{R}{2}$

Answer (4)

Sol. W.D. = $U_2 - U_1$

$$= -\frac{GMm}{R+R} - \left(\frac{-GMm}{R} \right)$$

$$= -\frac{GMm}{2R} + \frac{GMm}{R}$$

$$= \frac{GMm}{2R} = \frac{mgR}{2}$$

14. Each side of a metallic cube of mass 5.580 kg is measured to the 9.0 cm. Keeping the significant figures in view, the density of the material of the cube can be best expressed as $X \times 10^3 \text{ kg m}^{-3}$ where the value of X is:

- (1) 7.654 (2) 7.6
 (3) 7.65 (4) 7.7

Answer (4)

Sol. Density = $\frac{\text{Mass}}{\text{Volume}}$

$$= \frac{5.580 \text{ kg}}{(9.0 \text{ cm})^3}$$

$$= \frac{5.580}{729} \times 10^6 \frac{\text{kg}}{\text{m}^3}$$

$$= 0.007654321 \times 10^6 \frac{\text{kg}}{\text{m}^3}$$

$$= 7.654 \times 10^3 \frac{\text{kg}}{\text{m}^3}$$

$$= 7.7 \times 10^3 \frac{\text{kg}}{\text{m}^3}$$

Hence, on comparing

$$X = 7.7$$

15. The following plots show variation of velocity (v) with time (t) of a ball thrown vertically upward, and falling back. Which of the following plots is/are correct?

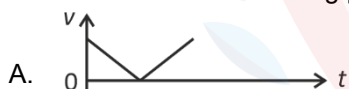

- (1) C only (2) D only
 (3) B only (4) A and E only

Answer (1)

Sol. During the whole journey, acceleration due to gravity is vertically downward.

Therefore, slope of velocity vs time curve should be negative throughout the journey.



\therefore Statement (C) is correct

16. The sum of kinetic energy and potential energy of a simple pendulum bob is 0.02 joule. The speed of the simple pendulum bob at equilibrium position is approximately:

(Consider mass of the bob = 20 g)

- (1) 0.2 m/s (2) 1.41 m/s
(3) 14.1 m/s (4) 2.0 m/s

Answer (2)

Sol. At equilibrium position

Total energy = K.E

$$\frac{1}{2}mv^2 = 0.02$$

$$\frac{1}{2} \times 20 \times v^2 \times 10^{-3} = 2 \times 10^{-2}$$

$$v = \sqrt{2}$$

$$v = 1.41 \text{ m/s}$$

17. In Young's double slit experiment, using monochromatic light of wavelength λ , the intensity of light at a point on the screen where the path difference is λ , is K units. The intensity of light at a point where the path difference is $\frac{\lambda}{3}$ will be

- (1) $\frac{K}{4}$ (2) K
(3) $2K$ (4) $\frac{K}{2}$

Answer (1)

Sol. $I = I_0 \cos^2 \frac{\Delta\phi}{2}$ [$I_0 \rightarrow$ maximum intensity]

$$I = I_0 \cos^2 \frac{K\Delta x}{2}$$

$$K = I_0 \cos^2 \left(\frac{2\pi}{\lambda} \times \frac{\lambda}{2} \right)$$

$$K = I_0$$

$$K_1 = I_0 \cos^2 \left(\frac{2\pi}{\lambda} \times \frac{\lambda}{3 \times 2} \right) = I_0 \cos^2 \left(\frac{\pi}{3} \right)$$

$$K_1 = \frac{I_0}{4}$$

$$\frac{K}{K_1} = 4 \Rightarrow K_1 = \frac{K}{4}$$

18. In the circuit shown below, the voltage appearing across the diode D will be of the form:

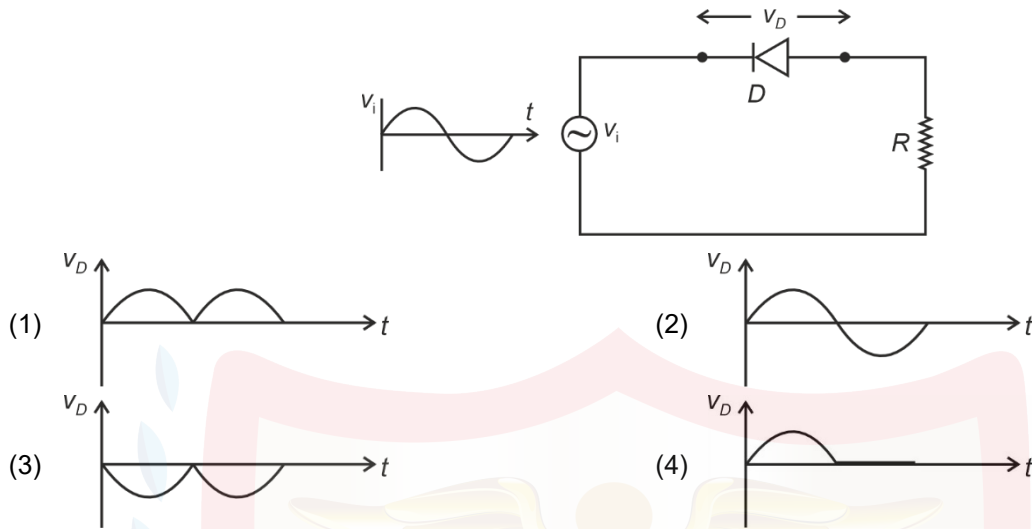

Answer (4)

Sol. Voltage drop will be across the diode, when it will be in reverse bias 1

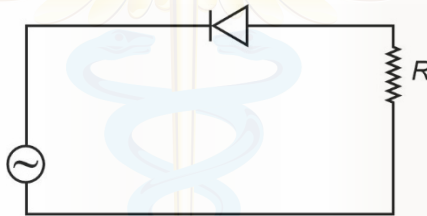

In positive half cycle it will be in reverse biased

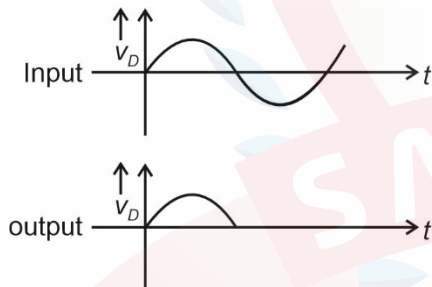

19. An ac circuit contains a resistance of $1\text{ k}\Omega$, a capacitor of $0.1\text{ }\mu\text{F}$ and an inductor of 1 mH connected in series. The resonance frequency of the circuit is approximately:

- (1) 13.5 kHz
- (2) 10.1 kHz
- (3) 20.7 kHz
- (4) 15.9 kHz

Answer (4)

Sol. Resonance frequency

$$f_0 = \frac{1}{2\pi\sqrt{LC}}$$

$$= \frac{1}{2\pi\sqrt{1 \times 10^{-7} \times 10^{-3}}}$$

$$= 15.9\text{ kHz}$$

23. Consider two uncharged capacitors of equal capacitance 200 pF. One of them is charged by a 100 V supply and disconnected. Now this capacitor is connected to the uncharged capacitor. The amount of electrostatic energy lost in the process is:

- (1) 0.5×10^{-6} J (2) 1.0 J
 (3) 1.0×10^{-6} J (4) 0.5 J

Answer (1)

Sol. Energy loss = $\frac{1}{2} \frac{C_1 C_2}{C_1 + C_2} V^2$

$$= \frac{1}{2} \left(\frac{200 \times 200}{400} \right) \times 10^{-12} (100)^2$$

$$= \frac{1}{2} \times 10^6 \times 10^{-12} = 0.5 \times 10^{-6} \text{ J}$$

24. The power of a crane, which lifts a mass of 1000 kg to a height of 20 m in 10 s is: ($g = 9.8 \text{ m/s}^2$)

- (1) 19.6 W (2) 39.2 W
 (3) 19.6 kW (4) 39.2 kW

Answer (3)

Sol. Power = $\frac{\text{Work}}{\text{Time}}$

$$= \frac{mgh}{t}$$

$$= \frac{10^3 \times 9.8 \times 20}{10} = 19.6 \text{ kW}$$

25. In a vernier calliper, 20 VSD coincide with 16 MSD (each division of length 1 mm). The least count of the vernier callipers is:

- (1) 0.2 cm (2) 0.01 cm
 (3) 0.02 cm (4) 0.1 cm

Answer (3)

Sol. Least count of vernier callipers

L.C. = 1 MSD – 1 VSD ... (i)

20 VSD = 16 MSD

1 VSD = $\frac{16}{20}$ MSD

From (i)

L.C. = 1 MSD – $\frac{16}{20}$ MSD

L.C. = $\frac{4}{20}$ MSD

L.C. = $\frac{1}{5}$ mm = 0.2 mm

L.C. = 0.02 cm

26. When a ruler falls vertically, 5 different persons catch it with different reaction times. ($g = 9.8 \text{ m s}^{-2}$)
- A. Person A has reaction time of 0.20 s. B. Person B has reaction time of 0.22 s.
 C. Person C has reaction time of 0.18 s. D. Person D has reaction time of 0.19 s.
 E. Person E has reaction time of 0.21 s.

What is the **correct** order of the distance travelled by the ruler for each person?

- (1) $B > E > A > C > D$ (2) $C > D > A > B > E$
 (3) $B > E > A > D > C$ (4) $C > D > A > E > B$

Answer (3)

Sol. → There will be large distance for large reaction time

→ Descending order of reaction time

⇒ $t_B > t_E > t_A > t_D > t_C$

→ Descending order of distance covered

⇒ $S_B > S_E > S_A > S_D > S_C$

27. A uniform metallic wire having resistance 4Ω is bent to form a square loop ($ABCD$) (see figure). A resistance of 2Ω is connected between points B and D and a battery of 2 V is connected across points A and C as shown in the figure. Now the value of current (I) is :

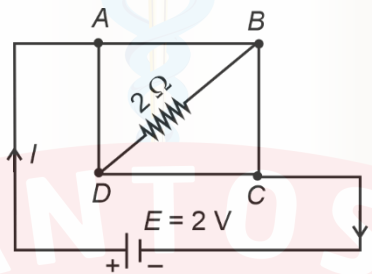

- (1) 2 A (2) 8 A
 (3) 4.5 A (4) 4 A

Answer (1)

Sol.

→ Each side will have resistance of 1Ω

→ It is balanced wheat stone bridge

→ No current in the resistance of 2Ω

→ $[R_{\text{effective}}]_{AC} = 1 \Omega$

→ $I = \frac{E}{R_{\text{eff.}}} = \frac{2}{1}$

→ $I = 2 \text{ A}$

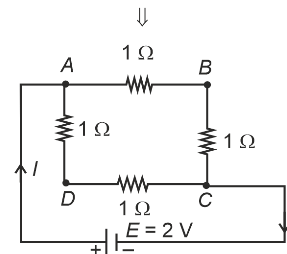
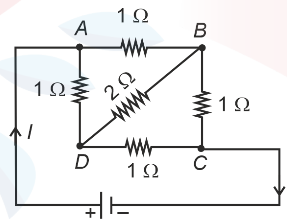

28. A room heater is rated 400 W, 220 V. If the supply voltage drops to 200 V, what will be the power consumed (approximately)?

- (1) 200 W (2) 400 W
 (3) 331 W (4) 121 W

Answer (3)

Sol. Rated power of heater

$$P_0 = \frac{V_0^2}{R} \quad \dots(i)$$

Consumed power

$$P_c = \frac{V^2}{R} \quad \dots(ii) \quad [V \rightarrow \text{applied voltage}]$$

From (i) and (ii)

$$\frac{P_c}{P_0} = \frac{V^2}{V_0^2}$$

$$P_c = \left[\frac{V}{V_0} \right]^2 P_0$$

$$P_c = \left[\frac{200}{220} \right]^2 \times 400$$

$$P_c = 331 \text{ W}$$

29. A 100-turn closely wound circular coil of radius 5 cm has a magnetic field of 3.14×10^{-3} T at its centre. The current flowing through the coil, and the magnitude of the magnetic moment of this coil are, respectively :

(Take $\mu_0 = 4\pi \times 10^{-7}$ T m/A)

- (1) 2 A, 10 A m² (2) 2.5 A, 20 A m²
 (3) 2 A, 4 A m² (4) 2.5 A, 2 A m²

Answer (4)

Sol. Magnetic field of a circular loop:

$$B_0 = \frac{\mu_0 Ni}{2R}$$

$$i = \frac{2RB_0}{\mu_0 N} = \frac{2 \times 5 \times 10^{-2} \times 3.14 \times 10^{-3}}{4\pi \times 10^{-7} \times 100}$$

$$i = 2.5 \text{ A}$$

Magnetic moment

$$M = NiA$$

$$= 100 \times 2.5 \times 3.14 \times (5 \times 10^{-2})^2 \quad [\because A = \pi R^2]$$

$$= 2 \text{ A m}^2$$

30. A rectangular wire loop of sides 8 cm and 3 cm with a small cut, is moving out of a region of uniform magnetic field of magnitude 0.3 T directed normal to the plane of the loop. The emf developed across the cut, if the velocity of the loop is 2 cm s⁻¹, in a direction normal to the shorter side of the loop, will be :
- (1) 4.8×10^{-4} volt (2) 1.2×10^{-4} volt
 (3) 1.3×10^{-4} volt (4) 1.8×10^{-4} volt

Answer (4)

Sol. Induced emf across the shorter side

$$\begin{aligned}
 E_{\text{induced}} &= Bvl \quad [\because \vec{B} \perp \vec{V} \perp \vec{l}] \\
 &= 0.3 \times 2 \times 10^{-2} \times 3 \times 10^{-2} \\
 &= 1.8 \times 10^{-4} \text{ V} \\
 &= 1.8 \times 10^{-4} \text{ volt}
 \end{aligned}$$

31. Four statements are given (A is mass number):
- A. The volume of a nucleus is proportional to $A^{1/3}$.
 B. The volume of a nucleus is proportional to A .
 C. The difference in mass of an atom and its nucleus is called the mass defect.
 D. The difference in mass of a nucleus and its constituents is called the mass defect.

Choose the **correct** answer from the options given below:

- (1) A and C are true, but B and D are false
 (2) B and C are true, but A and D are false
 (3) A and D are true, but B and C are false
 (4) B and D are true, but A and C are false

Answer (4)

Sol. As we know,

$$\begin{aligned}
 \text{Size of nucleus, } r &= r_0(A)^{\frac{1}{3}} \\
 \Rightarrow r^3 &= r_0^3 \cdot A \\
 \Rightarrow V &\propto A \quad \left(\because V = \frac{4}{3}\pi r^3 \right)
 \end{aligned}$$

So, option A → wrong and B → correct

while the difference between the actual mass of nucleus and its constituents is called the mass defect.

∴ option C → wrong and D → correct

32. An unknown nucleus has a nuclear density of 2.29×10^{17} kg/m³ and mass of 19.926×10^{-27} kg. Its mass number A is approximately:

(Take $R_0 = 1.2 \times 10^{-15}$ m, $4\pi = 12.56$)

- (1) 12 (2) 20
 (3) 16 (4) 19

Answer (1)

Sol. Given

$$\rho = 2.29 \times 10^{17} \text{ kg/m}^3, \text{ mass } m = 19.926 \times 10^{-27} \text{ kg}$$

$$R_0 = 1.2 \times 10^{-15} \text{ m and } R = R_0 A^{\frac{1}{3}}$$

$$\text{Now use volume} = \frac{\text{Mass}}{\text{Density}}$$

$$\Rightarrow \frac{4}{3} \pi R^3 = \frac{M}{\rho}$$

$$\Rightarrow \frac{4}{3} \pi [R_0(A)^{1/3}]^3 = \frac{M}{\rho}$$

$$\Rightarrow \frac{4}{3} \pi R_0^3 A = \frac{M}{\rho}$$

$$\Rightarrow A = \frac{M}{\rho} \times \frac{3}{4\pi R_0^3} = \frac{19.926 \times 10^{-27} \times 3}{2.29 \times 10^{17} \times 12.56 \times (1.2 \times 10^{-15})^3} \approx 12$$

33. Savitha, a XI standard student, while conducting an experiment to determine the effective length of a simple pendulum L , notes down the data of time taken to complete 30 oscillations as 60 s and hence calculates the length of the simple pendulum as: (Take $\pi^2 = 9.8$, and $g = 9.8 \text{ m/s}^2$)

(1) 0.75 m

(2) 1.5 m

(3) 2 m

(4) 1 m

Answer (4)

Sol. Time taken for 30 oscillations = 60 s

Time period of simple pendulum = Time taken for 1 oscillation

$$\Rightarrow T = \frac{60}{30} = 2 \text{ s}$$

$$T = 2\pi \sqrt{\frac{l}{g}} \Rightarrow l = \frac{gT^2}{4\pi^2} = \frac{9.8 \times 2 \times 2}{4 \times 9.8} = 1 \text{ m}$$

34. An electric heater supplies heat to a system at a rate of 100 W. If the system performs work at a rate of 75 J/s, then the rate at which internal energy increases will be:

(1) 75 W

(2) 100 W

(3) 125 W

(4) 25 W

Answer (4)

Sol. Using 1st law of thermodynamics for electric heater,

$$Q = \Delta U + W$$

$$\Rightarrow \frac{dQ}{dt} = \frac{d(\Delta U)}{dt} + \frac{dW}{dt}$$

$$\Rightarrow 100 \text{ W} = \frac{d(\Delta U)}{dt} + 75 \text{ W}$$

$$\therefore \frac{d(\Delta U)}{dt} = 25 \text{ W}$$

35. A thin wire of length 'L' and linear mass density 'm' is bent into a circular ring (in x-y plane) with centre 'C' as shown in figure. The moment of inertia of the ring about an axis yy' will be:

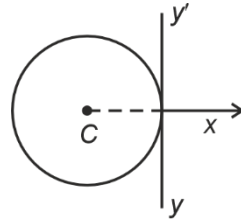

- (1) $\frac{3mL^3}{8\pi}$ (2) $\frac{3mL^3}{8\pi^2}$
 (3) $\frac{3mL^2}{8\pi}$ (4) $\frac{3mL^2}{8\pi^2}$

Answer (2)

Sol. Mass of thin wire = (Linear mass density) \times (Length)

$$\Rightarrow M = mL$$

$$L = 2\pi r, \text{ where } r = \text{radius of circular ring} = \frac{L}{2\pi}$$

Using parallel axis theorem,

$$I_{yy'} = I_{CM} + Mr^2 = \frac{Mr^2}{2} + Mr^2 = \frac{3}{2}Mr^2$$

$$\Rightarrow I_{yy'} = \frac{3}{2} \times (mL) \times \left(\frac{L}{2\pi}\right)^2 = \frac{3mL^3}{8\pi^2}$$

36. A galvanometer of resistance 100 Ω gives full scale deflection for a current of 1 mA. It is converted into an ammeter of range 0 – 10 A. The shunt required is:

- (1) 0.01 Ω (2) 0.10 Ω
 (3) 1.0 Ω (4) 0.001 Ω

Answer (1)

Sol. $i_G = 1 \text{ mA} = 0.001 \text{ A}$

$$i_s = 10 - i_G \approx 10 \text{ A}$$

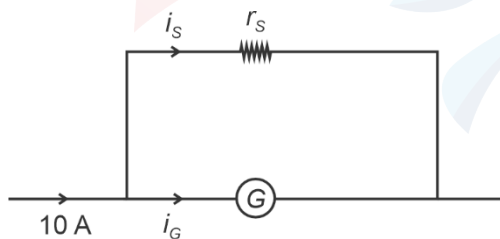

Both shunt resistance and galvanometer are in parallel connection

$$\therefore i_s r_s = i_G R_G$$

$$\Rightarrow 10 \times r_s = 0.001 \times 100$$

$$\Rightarrow r_s = 0.01 \Omega$$

37. In a metre bridge experiment (see figure), the positions of the cell, E , and galvanometer, G , are interchanged. We shall observe in the galvanometer:

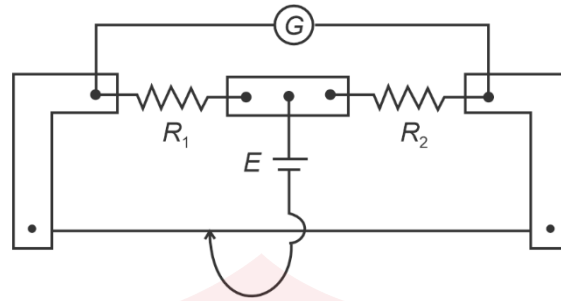

- (1) Only the left-sided deflection
- (2) There will be no deflection irrespective of the position of the jockey
- (3) Only the right-sided deflection
- (4) Both right-sided and left-sided deflection and at balance point, no deflection

Answer (4)

Sol.

- Position of null point will not change when galvanometer (G) and the cell (E) are interchanged.
- There will be no deflection in galvanometer only at balance point.

In an unbalanced meter bridge, if E and G are interchanged mutually, then the deflection in galvanometer may be towards left-side or right-side.

38. The peak value of an alternating current is 5 A and frequency is 60 Hz. How long will the current, starting from zero, take to reach the peak value?

- (1) $\frac{1}{120}$ s
- (2) $\frac{1}{60}$ s
- (3) $\frac{1}{30}$ s
- (4) $\frac{1}{240}$ s

Answer (4)

Sol. Alternating current,

$$i = i_{\text{peak}} \sin(\omega t)$$

$$\text{where } \omega = 2\pi f = 2\pi \times 60 = 120\pi \text{ rad/s}$$

$$\Rightarrow i = 5\sin(120\pi t)$$

$$\Rightarrow 5 = 5\sin(120\pi t)$$

$$\Rightarrow \sin(120\pi t) = 1 = \sin\left(\frac{\pi}{2}\right)$$

$$\therefore 120\pi t = \frac{\pi}{2}$$

$$\Rightarrow t = \frac{1}{240} \text{ s}$$

39. The figure given below shows a long straight solid wire of circular cross-section of radius 'a' carrying steady current I . The current I is uniformly distributed across its cross-section. The plot which correctly represents the variation of magnetic field (B) with distance (r) from the axis of the conductor in the region is :

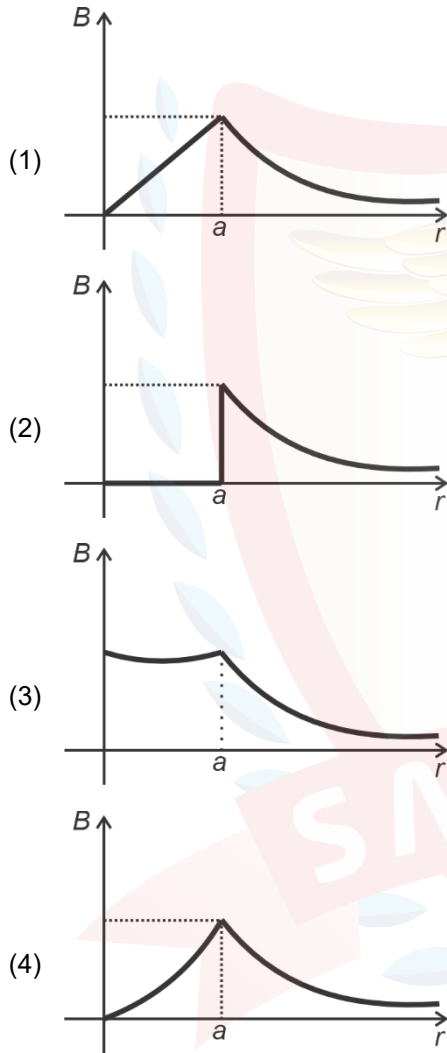
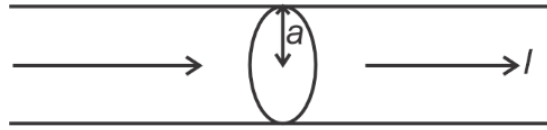

Answer (1)

Sol. For a long straight solid wire carrying steady current, which is uniformly distributed across its cross-section, the variation of magnetic field (B) with distance (r) from axis will be

$$B = \frac{\mu_0 I r}{2\pi a^2} \Rightarrow B \propto r, \text{ for } r < a$$

$$B = \frac{\mu_0 I}{2\pi r} \Rightarrow B \propto \frac{1}{r}, \text{ for } r > a$$

40. Two statements are given below:
- A. When the forward bias voltage across a p-n junction diode increases above a certain threshold voltage, the diode current increases significantly.
- B. This current is called reverse saturation current.

Choose the **correct** answer from the options given below:

- (1) Both Statements A and B are true
 (2) Statement A is true, but Statement B is false
 (3) Both Statements A and B are false
 (4) Statement A is false, but Statement B is true

Answer (2)

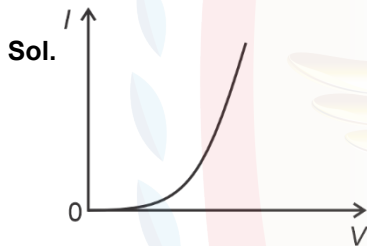

$V - I$ characteristics of a forward-biased junction diode

When forward bias voltage increases beyond threshold voltage, diode current increases significantly. This is not reverse saturation current.

41. Which of the following statements are correct?
- A. Inside a conductor, the electrostatic field is zero.
- B. Electric field at the surface of a charged conductor does not depend on its surface charge density.
- C. The interior of a charged conductor can have no excess charge in the static situation.
- D. At the surface of a charged conductor, the electrostatic field must be normal to the surface at every point.
- E. The electrostatic potential is zero everywhere inside a charged conductor.

Choose the **correct** answer from the options given below:

- (1) A, B and D only
 (2) A, C and E only
 (3) A, C and D only
 (4) C, D and E only

Answer (3)

Sol.

- A. Electrostatic field is zero inside a conductor.
- B. Electric field at the surface of a charged conductor = $\frac{\sigma}{\epsilon_0} \hat{n}$, depends on surface charge density (σ).
- C. The interior of a charged conductor cannot have any excess charge in the static situation.
- D. At the surface of a charged conductor, the electrostatic field \perp surface.
- E. The electrostatic potential is constant and can be non-zero everywhere inside a charged conductor.

42. For a metal of work function 6.6 eV, which of the following wavelengths of incident radiation does **not** give rise to the photoelectric effect?
 (Take Planck's constant as 6.6×10^{-34} J s)
- (1) 100 nm
 - (2) 150 nm
 - (3) 200 nm
 - (4) 50 nm

Answer (3)

Sol. For incident radiation having wavelength (λ), photoelectric effect doesn't occur when $\frac{hc}{\lambda} < \text{work-function}$

$$\Rightarrow \lambda > \frac{hc}{W_0}$$

$$\Rightarrow \lambda > \frac{6.6 \times 10^{-34} \times 3 \times 10^8}{6.6 \times 1.6 \times 10^{-19}}$$

$$\Rightarrow \lambda > \frac{3 \times 10^{-7}}{1.6}$$

$$\Rightarrow \lambda > \frac{300}{1.6} \text{ nm}$$

$$\Rightarrow \lambda = 187.5 \text{ nm}$$

\therefore Option (3) 200 nm is correct.

43. In a concave lens, a ray of light emanating from the object parallel to the principal axis of the lens after refraction:
- (1) passes through $2F$, which is the radius of curvature of the lens.
 - (2) appears to diverge from the first principal focus.
 - (3) emerges parallel to the principal axis.
 - (4) passes through the second principal focus.

Answer (2*)

Sol.

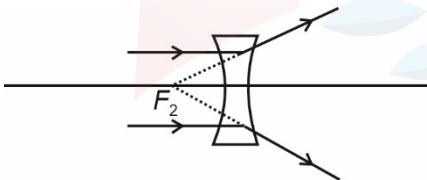

F_2 is the second principal focus \Rightarrow It is the virtual image position for object at infinity.

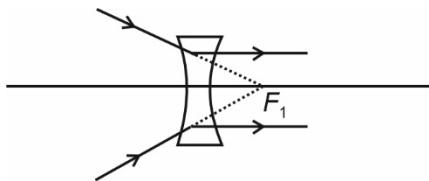

F_1 is the first principal focus \Rightarrow It is the virtual object position for which image is formed at infinity.

The best appropriate answer is option (2), although it should be second principal focus.

44. A submarine is designed to withstand an absolute pressure of 100 atm. How deep can it go below the water surface?

(Consider the density of water = 1000 kg m^{-3} ,
 $1 \text{ atm} = 1 \times 10^5 \text{ Pa}$ and gravitational acceleration $g = 10 \text{ m/s}^2$)

- (1) 990 m
 (2) 9900 m
 (3) 99 m
 (4) 9000 m

Answer (1)

Sol. $P = P_0 + \rho gh$

$$\Rightarrow 100 \times 10^5 = 10^5 + 10^3 \times 10 \times h$$

$$\Rightarrow 10^7 = 10^5 + 10^4 h$$

$$\Rightarrow 10^3 = 10 + h$$

$$\Rightarrow h = 1000 - 10 = 990 \text{ m}$$

45. Match List I with List II:

	List-I (Electromagnetic wave)		List-II (Production)
A.	Microwave	I.	Electrons in atoms emit light when they move from a higher energy level to a lower energy level
B.	Visible light	II.	Radioactive decay of nucleus
C.	Gamma rays	III.	Vibration of atoms and molecules
D.	Infra-red rays	IV.	Klystron valve or magnetron valve

Choose the **correct** answer from the options given below:

- (1) A-III, B-I, C-II, D-IV
 (2) A-III, B-IV, C-I, D-II
 (3) A-IV, B-I, C-II, D-III
 (4) A-IV, B-III, C-II, D-I

Answer (3)

Sol.

	List-I (Electromagnetic wave)	List-II (Production)
(A-IV)	Microwave	Klystron valve or magnetron valve
(B-I)	Visible light	Electrons in atoms emit light when they move from a higher energy level to a lower energy level
(C-II)	Gamma rays	Radioactive decay of nucleus
(D-III)	Infra-red rays	Vibration of atoms and molecules

CHEMISTRY

46. Select the reagents that reduce nitriles to primary amines.

- A. (i) LiAlH_4 ; (ii) H_2O
- B. $\text{Sn} + \text{HCl}$
- C. H_2/Ni
- D. $\text{Na(Hg)}/\text{C}_2\text{H}_5\text{OH}$
- E. $\text{Br}_2/\text{aq. NaOH}$

Choose the **correct** answer from the options given below.

- (1) B, D and E only
- (2) A, C and D only
- (3) A, D and E only
- (4) A, B and C only

Answer (2)

Sol.

- $\text{R}-\text{CN} \xrightarrow{\text{Na(Hg)}/\text{C}_2\text{H}_5\text{OH}} \text{R}-\text{CH}_2-\text{NH}_2$
- $\text{R}-\text{CN} \xrightarrow[\text{(ii) H}_2\text{O}]{\text{(i) LiAlH}_4} \text{R}-\text{CH}_2-\text{NH}_2$
- $\text{R}-\text{CN} \xrightarrow{\text{Sn+HCl}} \text{R}-\text{CHO}$
- $\text{R}-\text{CN} \xrightarrow{\text{H}_2/\text{Ni}} \text{R}-\text{CH}_2-\text{NH}_2$

47. Match List I with List II :

	List I (Transition metal/compound/ complex)		List II (Catalytic Role)
A.	V_2O_5	I.	Preparation of ammonia from N_2/H_2 mixture
B.	Fe	II.	Polymerisation of alkynes
C.	PdCl_2	III.	Preparation of H_2SO_4 and SO_2
D.	Ni complex	IV.	Oxidation of ethyne to ethanal

Choose the **correct** answer from the options given below.

- (1) A-III, B-IV, C-I, D-II
- (2) A-IV, B-I, C-III, D-II
- (3) A-II, B-I, C-IV, D-III
- (4) A-III, B-I, C-IV, D-II

Answer (4)

Sol. (A) $\text{V}_2\text{O}_5 \rightarrow$ Catalyses the oxidation of SO_2 into SO_3 in the manufacture of H_2SO_4 . (III)

(B) Fe \rightarrow Act as catalysts in preparation of ammonia from N_2/H_2 mixture. (I)

(C) $\text{PdCl}_2 \rightarrow$ Oxidation of ethyne to ethanal. (IV)

(D) Ni complex \rightarrow Polymerisation of alkynes. (II)

A \rightarrow III, B \rightarrow I, C \rightarrow IV, D \rightarrow II

Sol.

	List-I (Quantum Numbers)	List-II (Optical)	
	n	l	
A.	2	1	2p
B.	4	0	4s
C.	5	3	5f
D.	3	2	3d

l represents the subshell, for which the values are as following :

l	Subshell
0	s
1	p
2	d
3	f

50. In a qualitative analysis, Bi^{3+} is detected by appearance of precipitate of BiO(OH)(s) . Calculate pH when the following equilibrium exists at 298 K.

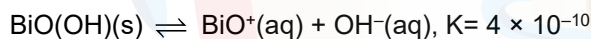

(Given : $\log 2 = 0.3010$)

- (1) 8.714
- (2) 4.699
- (3) 5.286
- (4) 9.301

Answer (4)

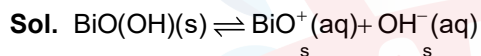

$$K = \frac{[\text{BiO}^+][\text{OH}^-]}{[\text{BiO(OH)(s)}]}$$

$$K = \frac{[\text{BiO}^+][\text{OH}^-]}{1}$$

$$K = s \times s = s^2$$

$$s = \sqrt{K} = \sqrt{4 \times 10^{-10}} = 2 \times 10^{-5} \text{ M}$$

$$[\text{H}^+] = \frac{K_w}{[\text{OH}^-]} = \frac{1}{2} \times 10^{-9}, \text{pH} = -\log[\text{H}^+] = 9 + \log 2 = 9.301$$

51. The correct statement with regard to the secondary structure of DNA/RNA is

- (1) RNA possesses a single strand helix structure and contains thymine as one of the four bases
- (2) DNA possesses a double strand helix structure and contains thymine as one of the four bases
- (3) RNA possesses a double strand helix structure and contains uracil as one of the four bases
- (4) DNA possesses a single strand helix structure and contains uracil as one of the four bases

Answer (2)

56. A bulb is rated at 150 watt, converting 8% energy into light. If energy of one photon is 4.42×10^{-19} J, how many photons are emitted by the bulb per second?
- (1) 2.71×10^{19}
 - (2) 4.06×10^{19}
 - (3) 27.2×10^{19}
 - (4) 1.35×10^{19}

Answer (1)

Sol.

$$\begin{aligned} \text{Energy} &= \text{Power} \times \text{time} \\ &= 150 \text{ watt} \times 1 \text{ s} \\ &= 150 \text{ J} \end{aligned}$$

$$\text{Energy converted to light} = \frac{150 \times 8}{100} = 12 \text{ J}$$

$$E = nh\nu$$

$$\text{Energy of one photon} = 4.42 \times 10^{-19}$$

$$\begin{aligned} \text{So, } n = \text{number of photons} &= \frac{E}{h\nu} = \frac{12}{4.42 \times 10^{-19}} \\ &= 2.715 \times 10^{19} \end{aligned}$$

57. Methane reacts with steam at 1273 K in the presence of nickel catalyst to form :
- (1) CO and H₂O
 - (2) CO₂ and H₂
 - (3) CO and H₂
 - (4) CO₂ and H₂O

Answer (3)

Sol.

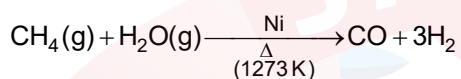

(Used for industrial preparation of dihydrogen gas)

58. Compound P(C₈H₈O) gives a red orange precipitate with 2,4-DNP reagent and it does not reduce Fehling's reagent. On drastic oxidation with chromic acid, P gives an aromatic product Q that produces effervescence on treating with aq. NaHCO₃. Compounds P and Q, respectively, are :

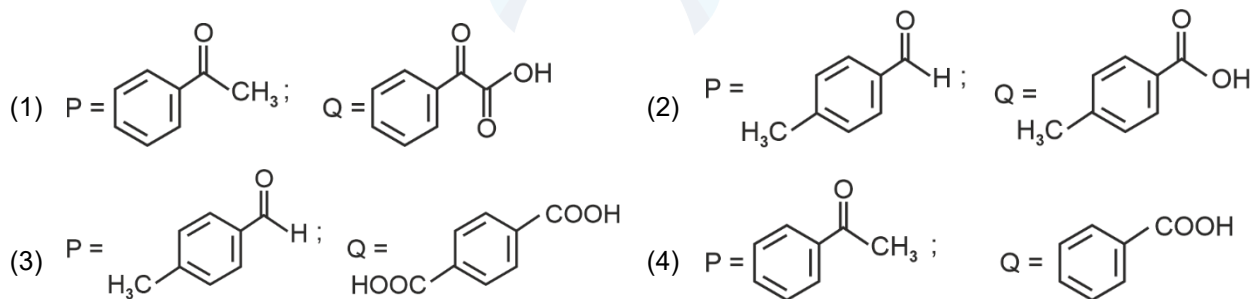

Answer (3 or 4)

Sol.

$$\text{Degree of unsaturation} = (8 + 1) - \left(\frac{8}{2}\right)$$

$$= 9 - 4 = 5$$

In question it is mentioned that oxidation under drastic condition, therefore it must be ketone

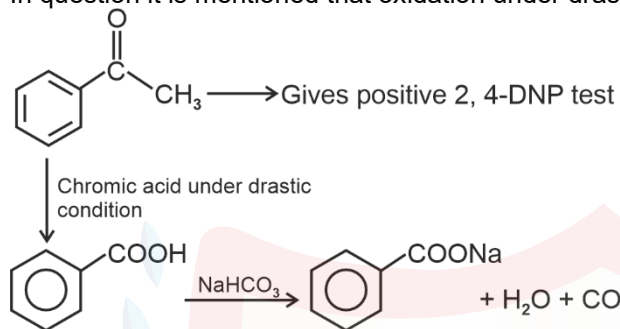

59. Match List I with List II :

	List I		List II
A.	C ₂ H ₄	I.	3 σ bonds, 2 π bonds
B.	C ₂ H ₂	II.	3 σ bonds, one lone pair
C.	CH ₄	III.	4 σ bonds
D.	NH ₃	IV.	5 σ bonds, 1 π bond

Choose the **correct** answer from the options given below :

(1) A-III, B-IV, C-II, D-I

(2) A-IV, B-I, C-III, D-II

(3) A-I, B-II, C-IV, D-III

(4) A-II, B-III, C-I, D-IV

Answer (2)

Sol.

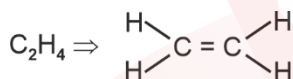

Number of σ bonds = 5

Number of π bond = 1

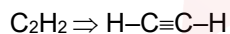

Number of σ -bonds = 3

Number of π -bonds = 2

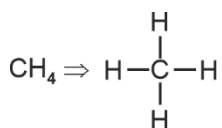

Number of σ -bonds = 4

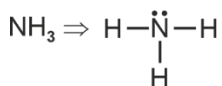

Number of σ -bonds = 3

Number of lone pair = one

A-IV, B-I, C-III, D-II

60. The following two reactions give the same foul smelling product Z.

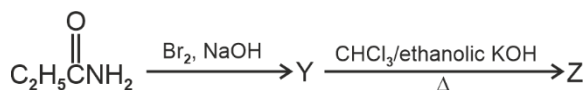
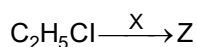

X and Z, respectively, are :

- (1) X = AgCN; Z = C₂H₅NC (2) X = KCN; Z = C₂H₅CN
 (3) X = AgCN; Z = C₂H₅CN (4) X = KCN; Z = C₂H₅NC

Answer (1)

Sol.

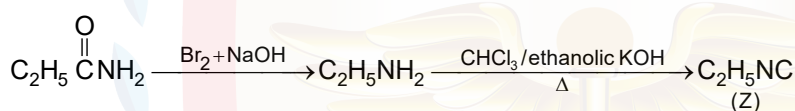
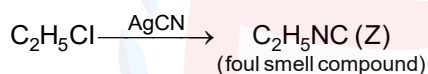

So, X = AgCN

Z = C₂H₅NC

61. The number of hydrogen atoms present in 5.4 g of urea is:

(Given: Molar mass of urea : 60 g mol⁻¹)

N_A : 6.022 × 10²³ particles mol⁻¹)

- (1) 1.084 × 10²³ (2) 1.084 × 10²²
 (3) 2.168 × 10²² (4) 2.168 × 10²³

Answer (4)

Sol.

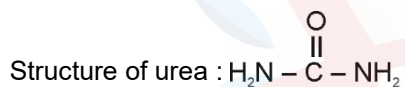

$$\text{Mole of urea} = \frac{5.4}{60} = 0.09$$

$$\begin{aligned} \text{Number of hydrogen atoms} &= 0.09 \times 4 \times 6.022 \times 10^{23} \\ &= 2.1679 \times 10^{23} \\ &\approx 2.168 \times 10^{23} \end{aligned}$$

62. Identify the **incorrect** statement from the following:

- (1) Nitrogen can form pπ-pπ multiple bonds with itself.
 (2) P(C₂H₅)₃ and As(C₆H₅)₃ form dπ-dπ bond with transition metals.
 (3) Phosphorus, arsenic and antimony show catenation property.
 (4) Nitrogen can form dπ-pπ bond with oxygen.

Answer (4)

Sol.

- Both nitrogen and oxygen do not contain d-orbitals so it cannot form dπ-pπ bond.
- Phosphorus and Arsenic can form dπ-dπ bond with transition metals. Since both have vacant d-orbitals by which it can interact with transition metals and can involve in dπ-dπ interaction.
- Phosphorous, Arsenic and Antimony show catenation property.

Choose the **correct** answer from the options given below :

(1) A-II, B-III, C-I, D-IV

(2) A-II, B-III, C-IV, D-I

(3) A-II, B-IV, C-III, D-I

(4) A-I, B-III, C-IV, D-II

Answer (2)

Sol.

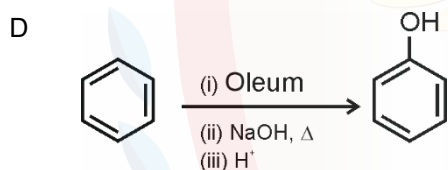
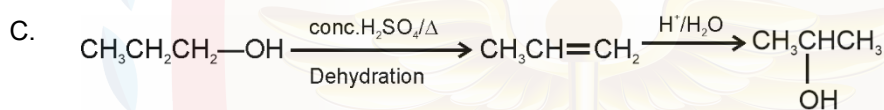
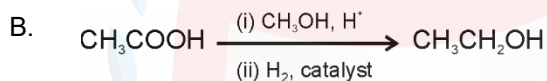
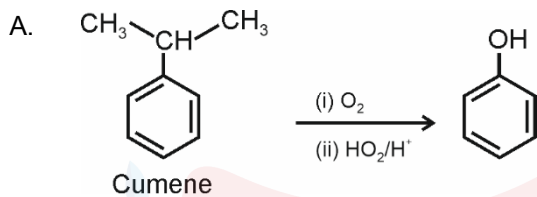

66. Although +3 oxidation state is most common in lanthanoids, cerium still shows +4 oxidation state because:

(1) After losing one more electron, it acquires $4f^{14}$ electronic configuration.

(2) Its nearest inert gas is Radon.

(3) Its atomic number is 61.

(4) After losing one more electron, it acquires $4f^0$ electronic configuration.

Answer (4)

Sol. Although +3 oxidation state is most common in lanthanoids, cerium still shows +4 oxidation state because after losing one more electron it acquires $4f^0$ electronic configuration.

67. In the following reaction sequence, X and Z respectively are :

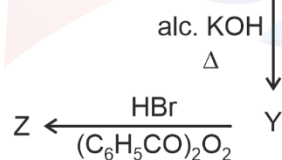

(1) $\text{X} = \text{POCl}_3$; $\text{Z} = \text{CH}_3 - \underset{\text{Br}}{\text{CH}} - \text{CH}_3$

(2) $\text{X} = \text{POCl}_3$; $\text{Z} = \text{CH}_3\text{CH}_2\text{CH}_2 - \text{Br}$

(3) $\text{X} = \text{H}_3\text{PO}_3$; $\text{Z} = \text{CH}_3 - \underset{\text{Br}}{\text{CH}} - \text{CH}_3$

(4) $\text{X} = \text{H}_3\text{PO}_3$; $\text{Z} = \text{CH}_3\text{CH}_2\text{CH}_2 - \text{Br}$

Answer (2)

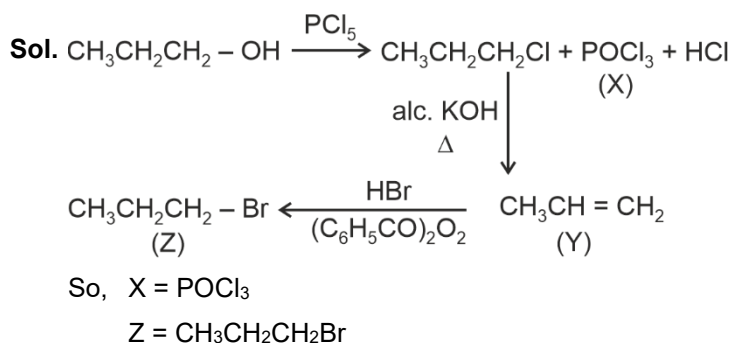

68. Match List I with List II :

	List I (Complex/ion)		List II (Shape/geometry)
A.	$[\text{Pt}(\text{Cl}_2)(\text{NH}_3)_2]$	(I)	Octahedral
B.	$[\text{Co}(\text{NH}_3)_6]\text{Cl}_3$	(II)	Trigonal bipyramidal
C.	$[\text{NiCl}_4]^{2-}$	(III)	Square planar
D.	$[\text{Fe}(\text{CO})_5]$	(IV)	Tetrahedral

Choose the **correct** answer from the options given below :

- (1) A-III, B-IV, C-I, D-II
- (2) A-III, B-I, C-IV, D-II
- (3) A-IV, B-I, C-III, D-II
- (4) A-I, B-III, C-IV, D-II

Answer (2)

Sol.

- In $[\text{Pt}(\text{Cl}_2)(\text{NH}_3)_2]$; Pt has dsp^2 hybridisation, so shape of complex is square planar.
- In $[\text{Co}(\text{NH}_3)_6]\text{Cl}_3$; Co has d^2sp^3 hybridisation so shape of complex is octahedral.
- In $[\text{NiCl}_4]^{2-}$; Ni has sp^3 hybridisation so shape of complex ion is tetrahedral.
- In $[\text{Fe}(\text{CO})_5]$; shape of complex is trigonal bipyramidal.

69. The functional group that can be identified through phthalein dye test is :

- (1) Aldehyde
- (2) Phenolic
- (3) Carboxylic acid
- (4) Alcohol

Answer (2)

Sol. Phthalein Dye test: Phenol on heating with phthalic anhydride in presence of concentrated sulphuric acid forms a colourless condensation compound called phenolphthalein. On further reaction with NaOH it gives pink colour.

So phenolic group is correct answer.

70. Two products X and Y are formed in the following reaction sequence.

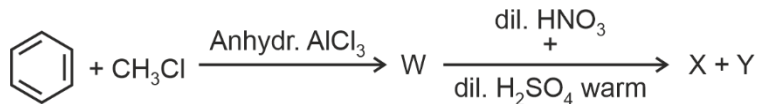

The suitable method that can be used for the separation of products X and Y is :

- (1) Fractional distillation (2) Sublimation
 (3) Differential extraction (4) Continuous extraction

Answer (1)

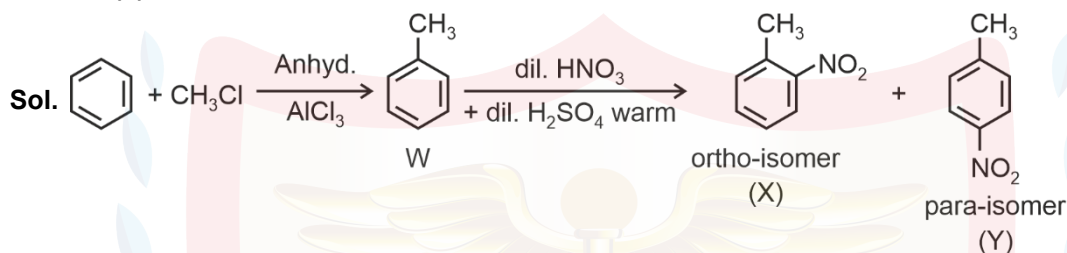

The ortho and para isomers are separated by fractional distillation under reduced pressure.

o-isomer, (M.P. $\rightarrow -4^\circ\text{C}$, B.P. $\rightarrow 222^\circ\text{C}$)

p-isomer, (M.P. $\rightarrow 54^\circ\text{C}$, B.P. $\rightarrow 238^\circ\text{C}$)

71. Identify the correct statements :

- (A) The molality of 2.5 g of ethanoic acid (Molar mass : 60 g mol^{-1}) in 75 g of benzene solution is 0.556 m.
 (B) The molarity of a solution containing 5 g of NaOH (molar mass : 40 g mol^{-1}) in 450 mL of solution is 0.278 M at 298 K.
 (C) Aquatic species are more comfortable in cold water.
 (D) The solubility of gas increases with decrease in pressure.
 (E) For a binary mixture of A and B, the number of moles of A and B are n_A and n_B respectively. The mole

fraction of B will be $x_B = \frac{n_B}{n_A + n_B}$.

Choose the **correct** answer from the options given below :

- (1) A, B and C only (2) A and B only
 (3) A and C only (4) A, D and E only

Answer (1)

Sol.

(A) Molality = $\frac{2.5}{60} \times \frac{1000}{75} = 0.556 \text{ molal}$

(B) Molarity = $\frac{5}{40} \times \frac{1000}{450} = 0.278 \text{ M}$

- (C) Aquatic species are more comfortable in cold water

Henry's Law $K_H \propto \text{Temp} \propto \frac{1}{\text{solubility}}$

- (D) According to Henry's Law,

$P = K_H X$

$P \propto x$

$P \propto \text{Solubility}$

So as $P \uparrow$, solubility \uparrow

(E) $x_B = \frac{n_B}{n_A + n_B}$

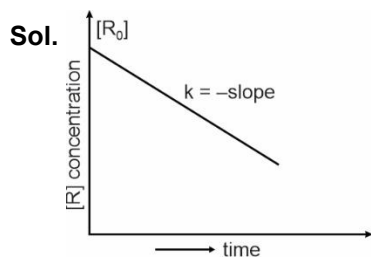

For zero order

$$[R] = [R_0] - kt$$

So -ve slope shows zero order reaction

76. Identify the correct statement about ClF_3 from the following options :

- (1) It has T-shaped geometry with two lone pairs on Cl atom.
- (2) It has T-shaped geometry with three lone pairs on Cl atom.
- (3) It has a trigonal pyramidal geometry with two lone pairs on Cl atom.
- (4) It has a planar trigonal geometry with two lone pairs on Cl atom.

Answer (1)

Sol. ClF_3 has two lone pairs of electrons on Cl atom with bent T-shape structure (geometry)

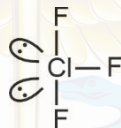

77. In a test tube containing a salt, a few drops of dilute H_2SO_4 was added, which gave colourless vapours having the smell of vinegar. The vapours turned the blue litmus paper red.

Identify the **correct** anion from the following :

- | | |
|--|-----------------------------------|
| (1) Sulphide, S^{2-} | (2) Sulphate, SO_4^{2-} |
| (3) Acetate, CH_3COO^- | (4) Carbonate, CO_3^{2-} |

Answer (3)

Sol.

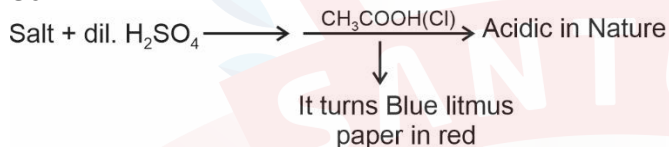

So, correct Answer is : Acetate, CH_3COO^-

78. At 298 K, a certain buffer solution contains equal concentrations of X^- and HX , K_b for X^- is 10^{-10} . What is the pH of this buffer solution?

- | | |
|-------|--------|
| (1) 2 | (2) 4 |
| (3) 6 | (4) 10 |

Answer (2)

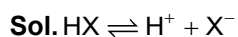

$$K_a \times K_b = K_w$$

$$K_a = \frac{K_w}{K_b} = \frac{10^{-14}}{10^{-10}} = 10^{-4}$$

$$\text{pH} = \text{p}K_a + \log \frac{[\text{X}^-]}{[\text{HX}]}$$

Given that : $[\text{X}^-] = [\text{HX}]$

$$= 4 + \log(1)$$

$$= 4 + 0$$

$$= 4$$

79. Calculate emf of the half cell given below :

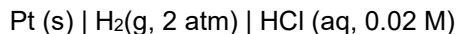

$$E_{\text{H}_2/\text{H}^+}^\circ = 0 \text{ V}$$

$$\text{(Given: } \frac{2.303 RT}{F} = 0.059, \log 2 = 0.3010)$$

$$(1) -0.109 \text{ V}$$

$$(2) 0.035 \text{ V}$$

$$(3) -0.035 \text{ V}$$

$$(4) 0.109 \text{ V}$$

Answer (4)

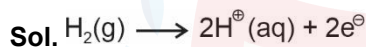

$$\therefore E = E^\circ - \frac{2.303RT}{nF} \log \frac{[\text{H}^\oplus]^2}{P_{\text{H}_2}}$$

$$[\text{H}^\oplus] = 0.02 \text{ M (from HCl)}$$

$$P_{\text{H}_2} = 2 \text{ atm}$$

$$\frac{2.303RT}{F} = 0.059$$

$$E = 0 - \frac{0.059}{2} \log \frac{(0.02)^2}{2}$$

$$= -0.0295 \log \left(\frac{0.0004}{2} \right)$$

$$E = -0.0295 \log(2 \times 10^{-4})$$

$$= -0.0295 (\log 2 + \log 10^{-4})$$

$$= -0.0295 [0.301 - 4] = 0.109 \text{ V}$$

80. The calculated 'spin-only' magnetic moment $\text{Ti}^{2+} (3d^2)$ is :

$$(1) 5.92 \text{ BM}$$

$$(2) 3.87 \text{ BM}$$

$$(3) 2.84 \text{ BM}$$

$$(4) 4.90 \text{ BM}$$

Answer (3)

Sol. Spin only magnetic moment $\mu = \sqrt{n(n+2)} \text{ B.M}$

n = Number of unpaired e^- (s)



$$\mu = \sqrt{2 \times 4}$$

$$= 2.84 \text{ BM}$$

81. Identify the **incorrect** statement from the following:

(1) Carbon has the ability to form $p\pi-p\pi$ multiple bond with itself.

(2) ECl_3 (E = B and Al) is a monomer when E = B and a dimer when E = Al.

(3) The order of catenation property of Group 14 elements is $\text{C} \gg \text{Si} > \text{Ge} \approx \text{Sn}$.

(4) Oxygen exhibits only -2 oxidation state.

Answer (4)

Sol.

(1) C can form $p\pi-p\pi$ multiple bond with itself.

It is observed when it forms $C = C$ and $C \equiv C$

(2) ECl_3 (E = B and Al)

BCl_3 does not form dimer.

$AlCl_3$ can form dimer in Al_2Cl_6 .

(3) Catenation property of group 14 $C \gg Si > Ge \approx Sn$.

(4) Oxygen exhibits oxidation state of 0 in O_2 , -2 in oxides, -1 in peroxides. So this statement is incorrect.

82. The correct formal charges on oxygen atoms numbered 2, 1 and 3 respectively are :

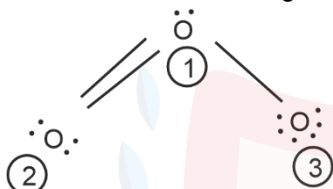

(1) -1, 0, +1

(2) 0, +1, -1

(3) 0, 0, 0

(4) +1, 0, -1

Answer (2)

Sol.

$$\text{Formal charge} = \text{Valence electrons}_{(V)} - \frac{1}{2} (\text{shared electrons}_{(S)}) - (\text{non-bonding electrons}_{(L)})$$

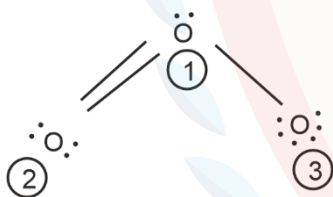

$$\text{Formal charge on 2}^{\text{nd}} \text{ oxygen atom} = 6 - \frac{1}{2}(4) - 4 = 0$$

$$\text{Formal charge on 1}^{\text{st}} \text{ oxygen atom} = 6 - \frac{1}{2}(6) - 2 = +1$$

$$\text{Formal charge on 3}^{\text{rd}} \text{ oxygen atom} = 6 - \frac{1}{2}(2) - 6 = -1$$

83. Phenolphthalein is used as an indicator for the titration of sodium hydroxide solution against a standard solution of oxalic acid. The colour change that is observed at an alkaline pH close to the equivalence point during this titration is:

(1) pinkish red to yellow

(2) yellow to pinkish red

(3) pink to colourless

(4) colourless to pink

Answer (4)

Sol.

Colour of Phenolphthalein before the end point = colourless.

Colour of Phenolphthalein close to equivalence point = Pink.

\therefore Colour change = Colourless to pink.

84. When 1 dm³ of CO₂ gas is passed over hot coke the volume of gaseous mixture after complete reaction at STP becomes 1.4 dm³. The composition of the gaseous mixture at STP is:
- (1) 0.8 dm³ of CO, 0.8 dm³ of CO₂
 - (2) 0.8 dm³ of CO, 0.6 dm³ of CO₂
 - (3) 0.6 dm³ of CO, 0.8 dm³ of CO₂
 - (4) 0.6 dm³ of CO, 0.4 dm³ of CO₂

Answer (2)

Sol.

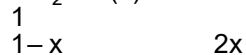
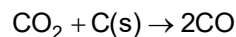

$$1 - x + 2x = 1 + x = 1.4$$

$$x = 0.4 \text{ dm}^3$$

$$\text{Volume of CO}_2 = 1 - 0.4 = 0.6 \text{ dm}^3$$

$$\text{Volume of CO} = 2 \times 0.4 = 0.8 \text{ dm}^3$$

85. The major product Z formed in the following sequence of reactions is

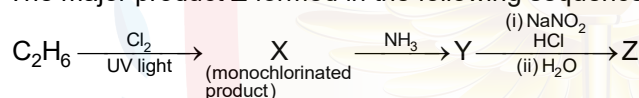

- (1) C₂H₅NO₂
- (2) C₂H₅-N=N-OH
- (3) C₂H₅OH
- (4) C₂H₅NH₂

Answer (3)

Sol.

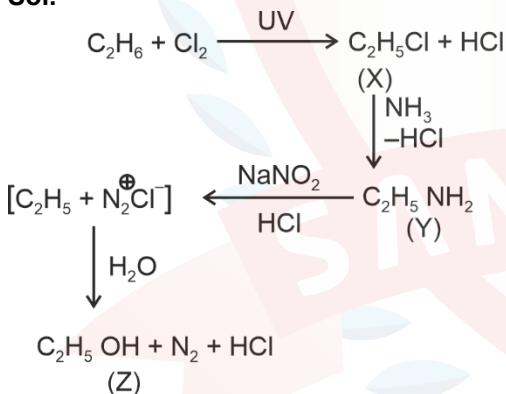

86. Given below is an expression for the rate constant of a first-order reaction occurring at a certain temperature, T (K).

$$\ln k = 14.34 - \frac{1.25 \times 10^4}{T}$$

The energy of activation in kcal mol⁻¹ for the reaction is :

(Given: k in s⁻¹, R = 1.987 cal mol⁻¹ K⁻¹)

- (1) 24.84
- (2) 14.34
- (3) 18.63
- (4) 12.42

Answer (1)

Sol.

From Arrhenius equation

$$k = A e^{\frac{-E_a}{RT}}$$

$$\ln k = \ln A - \frac{E_a}{RT}$$

$$\frac{E_a}{R} = 1.25 \times 10^4$$

$$E_a = 1.25 \times 10^4 \times 1.987$$

$$= 24.84 \text{ k cal mol}^{-1}$$

87. Given below are certain reactions. Identify the reaction for which $K_P \neq K_C$.

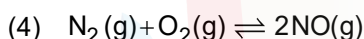
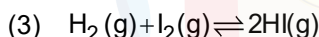
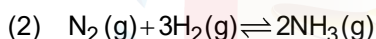
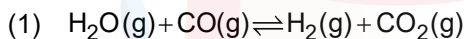

Answer (2)

Sol.

$$K_P = K_C (RT)^{\Delta n_g}$$

For $K_P = K_C$ ($\Delta n_g = 0$)

$$K_P \neq K_C \text{ } (\Delta n_g \neq 0)$$

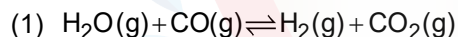

$$\Delta n_g = 0 \text{ } (K_P = K_C)$$

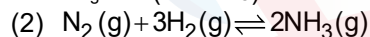

$$\Delta n_g = -2 \text{ } (K_P \neq K_C)$$

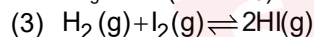

$$\Delta n_g = 0 \text{ } (K_P = K_C)$$

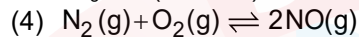

$$\Delta n_g = 0 \text{ } (K_P = K_C)$$

88. Identify the **incorrect** statement from the following :

(1) The largest and the smallest species among Mg, Mg^{2+} , Al and Al^{3+} are Al and Mg^{2+} respectively.

(2) The IUPAC name of the element with atomic number 107 is Unnilseptium.

(3) The similarity in behaviour of Li with Mg is referred to as 'diagonal relationship'

(4) The oxidation state and covalency of Al in $[\text{AlCl}(\text{H}_2\text{O})_5]^{2+}$ are 3 and 6, respectively.

Answer (1)

Sol.

The largest species is Mg and the smallest one is Al^{3+} among Mg, Mg^{2+} , Al and Al^{3+} .

- Unnilseptium element has atomic number 107
- Li and Mg are diagonally related and have similar properties.
- The oxidation state and covalency of Al in $[\text{AlCl}(\text{H}_2\text{O})_5]^{2+}$ are +3 and 6 respectively

\therefore Statement A is incorrect

89. Mixture of chloroform and acetone forms a solution with negative deviation from Raoult's law due to :
- (1) Increase in escaping tendency of molecules of each component.
 - (2) Formation of hydrogen bonding between acetone and chloroform
 - (3) Stronger intermolecular forces between chloroform molecules than those between chloroform and acetone molecules.
 - (4) Repulsive forces.

Answer (2)

Sol.

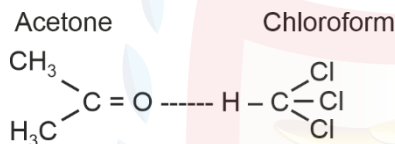

Acetone and chloroform show negative deviation from Raoult's law due to stronger H-bonding between acetone and chloroform mixture.

Hence, escaping tendency decreases

∴ Vapour pressure decreases

∴ Boiling point increases.

90. The number of chlorine atoms present in the organic products X and Y of the following reactions, respectively, are :

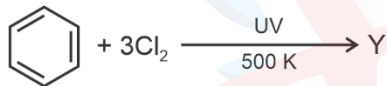
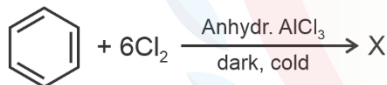

- (1) 3 and 3
- (2) 6 and 3
- (3) 6 and 6
- (4) 3 and 6

Answer (3)

Sol.

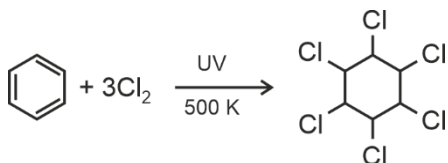
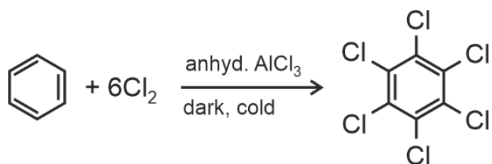

BIOLOGY

91. In angiosperms, root hairs arise from which one of the following regions of the root?

- (1) The root cap zone
- (2) The region of meristematic activity
- (3) The region of elongation
- (4) The region of maturation

Answer (4)

Sol. From the region of maturation, some epidermal cells form very fine and delicate, thread like structures called root hairs.

92. In which one of the following, the ovules are **not** enclosed by an ovary wall and remain exposed?

- (1) *Funaria*
- (2) *Pinus*
- (3) *Selaginella*
- (4) *Wolffia*

Answer (2)

Sol. The gymnosperms are plants in which the ovules are not enclosed by any ovary wall and remain exposed, both before and after fertilisation.

Pinus is a gymnosperm.

Funaria is a moss.

Selaginella is a pteridophyte.

93. In the *lac* operon, the *z* gene codes for

- (1) permease
- (2) transacetylase
- (3) beta-galactosidase
- (4) the repressor of *lac* operon

Answer (3)

Sol. In *lac* operon,

i gene codes for – regulator protein

z gene codes for – beta-galactosidase

y gene codes for – Permease

a gene codes for – transacetylase

94. Exploring molecular, genetic and species-level diversity for products of economic importance is called

- (1) Biofortification
- (2) Bioremediation
- (3) Bioprospecting
- (4) Biomagnification

Answer (3)

Sol. Exploring molecular, genetic and species – level diversity for products of economic importance is called as bioprospecting.

95. Match List I with List II:

	List-I		List-II
A.	Genetically modified organism	(I)	<i>Agrobacterium tumefaciens</i>
B.	Thermostable DNA polymerase	(II)	Bt cotton
C.	Ti plasmid	(III)	<i>Thermus aquaticus</i>
D.	pBR322	(IV)	<i>Escherichia coli</i>

Choose the **correct** answer from the options given below:

- (1) A-II, B-III, C-I, D-IV
- (2) A-II, B-I, C-IV, D-III
- (3) A-I, B-IV, C-III, D-II
- (4) A-I, B-II, C-IV, D-III

Answer (1)

Sol. Genetically modified organism – Bt cotton

Thermostable DNA polymerase – *Thermus aquaticus*.

Ti plasmid – *Agrobacterium tumefaciens*

pBR322 – *Escherichia coli*

96. Match List I with List II :

	List I		List II
A.	Productivity	I.	Gross primary productivity minus respiration losses
B.	Net primary productivity	II.	Rate of formation of new organic matter by consumers
C.	Gross primary productivity	III.	Rate of biomass production
D.	Secondary productivity	IV.	Rate of production of organic matter during photosynthesis

Choose the **correct** answer from the options given below :

- (1) A-III, B-I, C-IV, D-II
- (2) A-I, B-II, C-III, D-IV
- (3) A-I, B-III, C-IV, D-II
- (4) A-III, B-I, C-II, D-IV

Answer (1)

Sol. Productivity is the rate of biomass production.

Net primary productivity is the Gross primary productivity (GPP) minus respiration losses (R).

Gross primary productivity is the rate of production of organic matter during photosynthesis.

Secondary productivity is the rate of formation of new organic matter by consumers.

97. Since the origin and diversification of life on Earth, there have been five episodes of mass extinction of species. How is the sixth extinction, which is in progress, different from the previous episodes?

- (1) The present net species extinction rate is zero.
- (2) The current species extinction rate is nearly 10 times faster than in previous episodes.
- (3) The present species extinction rates are 100 to 1000 times faster than in the pre-human times.
- (4) The current species extinction rates are far lower than those in previous episodes.

Answer (3)

Sol. The current, sixth episode of mass extinction is estimated to be 100 to 1000 times faster than the ones in the pre-human times and our activities are responsible for the faster rates.

98. Alpha-helix is found in which level of protein structure?

- (1) Secondary structure
- (2) Tertiary structure
- (3) Primary structure
- (4) Quaternary structure

Answer (1)

Sol. Alpha-helix is shown by secondary structure of protein as it has right handed helices.

Primary structure is linear and tertiary structure is a hollow ball-like structure. Quaternary structures are formed by more than one polypeptide chains.

99. The main function of bulliform cells in grasses is :

- (1) to make the leaf impermeable to fungal spores.
- (2) to transport water.
- (3) to perform photosynthesis.
- (4) to minimize water loss during water stress.

Answer (4)

Sol. Bulliform cells are large empty colourless cells that lose water and become flaccid in water scarce condition. Hence they curl the leaf inwards to minimise water loss by reducing the exposed surface area.

100. Identify the **correct** sequence of steps in each cycle of Polymerase Chain Reaction :

- (1) Extension → Annealing → Denaturation
- (2) Annealing → Denaturation → Extension
- (3) Denaturation → Extension → Annealing
- (4) Denaturation → Annealing → Extension

Answer (4)

Sol. The correct sequence of steps in PCR is

Denaturation → Annealing → Extension

101. Match List I with List II :

	List-I (Phase of cell cycle)		List-II (Activity)
A.	G ₁ phase	I.	Actual cell division occurs
B.	S phase	II.	Cell is metabolically active and continuously grows but does not replicate its DNA
C.	G ₂ Phase	III.	Synthesis of DNA occurs and the amount of DNA per cell doubles
D.	M phase	IV.	Proteins are synthesized while cell growth continues

Choose the **correct** answer from the options given below :

- (1) A-IV, B-I, C-II, D-III
- (2) A-I, B-II, C-III, D-IV
- (3) A-III, B-IV, C-I, D-II
- (4) A-II, B-III, C-IV, D-I

Answer (4)

Sol. During G₁ phase the cell is metabolically active and continuously grows but does not replicate its DNA.

S-phase marks the phase during which DNA synthesis or replication takes place and amount of DNA per cell doubles.

During the G₂ phase, proteins are synthesised in preparation for mitosis while cell growth continues.

During M phase the actual cell division takes place.

102. Which of the following statements are correct?

- A. The Amazon rainforest being cut and cleared for cultivation of soyabeans is an example of habitat loss.
- B. Steller's sea cow and passenger pigeon became extinct due to over-exploitation by humans.
- C. The Nile perch introduced into Lake Victoria in East Africa helped in population growth of cichlid fish in the lake.
- D. Water hyacinth is an invasive species.
- E. When a species becomes extinct, the plant and animal species associated with it are not affected.

Choose the **correct** answer from the options given below:

- (1) A, B and E only
- (2) A, B and D only
- (3) C, D and E only
- (4) B, C and D only

Answer (2)

Sol. The Nile Perch introduced into Lake Victoria in East Africa led eventually to extinction of an ecologically unique assemblage of more than 200 species of cichlid fish in the lake.

When a species become extinct, the plant and animal species associated with it in an obligatory way also become, extinct.

Statements, A, B and D are correct.

103. Which of the following statements are correct with reference to a transcription unit?
- A transcription unit in DNA is defined primarily by three regions : promoter, structural gene and terminator.
 - The promoter is said to be located towards the 5'-end of the structural gene.
 - The promoter is a DNA sequence that provides binding site for RNA polymerase.
 - The promoter defines the template and coding strands.
 - The terminator is located towards the 3'-end of the coding strand and it defines the end of the process of transcription.

Choose the **correct** answer from the options given below:

- (1) A, B, C and D only
- (2) A, C, D and E only
- (3) B, C, D and E only
- (4) A, B, C, D and E

Answer (4)

Sol. The promoter and terminator flank the structural gene in a transcription unit.

The promoter is said to be located towards 5'-end of the structural gene.

It is a DNA sequence that provides binding site for RNA polymerase and it is the presence of promoter in a transcription unit that also defines the template and coding strands.

The terminator is located towards 3'-end of the coding strand and it usually defines the end of transcription.

104. Which one of the following statements is **not** true about the universal rules of binomial nomenclature?
- (1) Biological names are generally in Latin
 - (2) Both the words in a biological name, when handwritten, are separately underlined or printed in italics
 - (3) The specific epithet in the biological name starts with a small letter
 - (4) The first word in the biological name represents the specific epithet, while the second component denotes the genus

Answer (4)

Sol. According to universal rules of nomenclature, the first word denoting the genus starts with a capital letter with the second components denotes the specific epithet and starts with small letter.

105. Match List I with List II:

	List-I		List-II
A.	Decomposition	I.	Accumulation of dark coloured amorphous colloidal substance
B.	Detritus	II.	Release of inorganic nutrients by the activity of microbes in soil
C.	Mineralisation	III.	Breaking down of complex organic matter into inorganic substances.
D.	Humification	IV.	Dead remains of plants and animals including fecal matter

Choose the **correct** answer from the options given below:

- (1) A-IV, B-III, C-I, D-II
- (2) A-III, B-IV, C-II, D-I
- (3) A-I, B-II, C-III, D-IV
- (4) A-III, B-II, C-I, D-IV

Answer (2)

Sol. Decomposition is the process of breaking down of complex organic matter into inorganic substance.

Detritus includes dead remains of plants and animals including fecal matter and acts as the raw material for decomposition.

Degradation of humus by activity of microbes leading to release of inorganic nutrients is called **Mineralisation**.

Accumulation of the dark coloured amorphous substance called humus, is called **humification**.

106. Which one of the following is the site for active ribosomal RNA synthesis?

- (1) Centrosome (2) Chromatin
(3) Nucleolus (4) Kinetochore

Answer (3)

Sol. Nucleolus is the site for active ribosomal RNA synthesis.

107. $2(C_{51}H_{98}C_6) + 145 O_2 \rightarrow 102 CO_2 + 98 H_2O + \text{energy}$

The Respiratory Quotient (RQ) of a biomolecule used for respiration, as per the above equation would be :

- (1) Between 0.5 and 0.95
(2) Less than 0.5
(3) 1.0
(4) Between 1.25 and 2

Answer (1)

Sol. $R.Q = \frac{\text{Volume of } CO_2 \text{ evolved}}{\text{Volume of } O_2 \text{ consumed}}$

As per the given equation,



Hence the RQ can be calculated as,

$$R.Q = \frac{102}{145} = 0.7$$

This value lies between 0.5 and 0.95.

108. Match List I with List II :

	List-I		List-II
A.	Incomplete dominance	I.	Human skin colour
B.	Co-dominance	II.	Inheritance of flower colour in <i>Antirrhinum</i> sp.
C.	Pleiotropy	III.	Phenylketonuria disease in humans
D.	Polygenic inheritance	IV.	ABO blood groups

Choose the **correct** answer from the options given below :

- (1) A-II, B-IV, C-III, D-I (2) A-I, B-III, C-II, D-IV
(3) A-I, B-IV, C-III, D-II (4) A-II, B-I, C-III, D-IV

Answer (1)

Sol. Inheritance of flower colour in snapdragon (*Antirrhinum* sp.) is an example of incomplete dominance.

ABO blood groups exhibit codominance in case of individuals having AB blood group ($I^A I^B$)

Phenylketonuria in humans is an example of pleiotropy since the gene responsible for it leads to multiple phenotypic effects.

Human skin colour is controlled by three pairs of non allelic genes, hence it is an example of polygenic inheritance.

109. Arrange the following steps of DNA fingerprinting in a correct sequence.

- A. Isolation of DNA and its digestion by restriction endonucleases.
- B. Hybridisation using a labelled VNTR probe.
- C. Transferring of separated DNA fragments to synthetic membranes.
- D. Detection of hybridised DNA fragments by autoradiography.
- E. Separation of DNA fragments by electrophoresis.

Choose the **correct** answer from the options given below :

- (1) A, B, D, C, E
- (2) A, D, B, E, C
- (3) A, E, C, B, D
- (4) A, E, B, C, D

Answer (3)

Sol. The following is the correct sequence of steps of DNA fingerprinting.

- A. Isolation of DNA and its digestion by restriction endonuclease.
- B. Probes made complementary to the VNTR locus are allowed to hybridise with the DNA fragments.
- C. The separated DNA fragments are transferred to synthetic membranes made of nylon or nitrocellulose.
- D. Finally, the hybridised DNA fragments are detected under X-rays in a technique called autoradiography.
- E. DNA fragments are separated based on their size by the technique of gel electrophoresis.

110. Which of the following statements are correct with reference to packaging of DNA helix ?

- A. Histones are organized to form a unit of eight molecules called histone octamer.
- B. Histones are negatively charged basic proteins.
- C. Histones are rich in the basic amino acid residues - lysine and arginine.
- D. The positively charged DNA is wrapped around the histone octamer to form nucleosome.
- E. The packaging of chromatin at higher levels requires an additional set of proteins called non-histone chromosomal proteins.

Choose the **correct** answer from the options given below :

- (1) A, C and E only
- (2) B, D and E only
- (3) C, D and E only
- (4) A, B and D only

Answer (1)

Sol. Eight Histones are combined to form a histone octamer. Histones are positively charged basic proteins that are rich in basic amino acids (lysine and arginine). The negatively charged DNA is wrapped around the histone octamer to form nucleosome. The packaging of chromatin at higher levels require NHC (non histone chromosomal) proteins.

111. Find the **incorrect** statement(s) about photosynthesis from the following:

- A. The water splitting complex is associated with PS I.
- B. C_4 plants use the C_3 pathway of CO_2 fixation as the main biosynthetic pathway.
- C. In C_4 plants, photorespiration does not occur.
- D. C_3 plants exhibit 'Kranz' anatomy.
- E. ATP synthesis in chloroplast occurs through chemiosmosis.

Choose the answer from the options given below:

- (1) B and C only
- (2) B only
- (3) B and E only
- (4) A and D only

Answer (4)

Sol. The water splitting complex is associated with PS-II. C_3 pathway is the main biosynthetic pathway for CO_2 fixation in both C_3 and C_4 plants.

C_3 plants do not exhibit 'kranz' anatomy.

ATP synthesis in chloroplast (Photophosphorylation) occurs by chemiosmosis.

112. Arrange the following steps of somatic hybridisation in a correct sequence.

- A. Digestion of cell walls.
- B. Isolation of naked protoplasts.
- C. Fusion of protoplasts to get hybrid protoplast.
- D. Isolation of single cells from two different varieties of plants.
- E. Growing of hybrid protoplast to form a new plant.

Choose the **correct** answer from the options given below:

- (1) D, A, B, C, E
- (2) E, B, A, D, C
- (3) D, B, A, E, C
- (4) E, A, B, C, D

Answer (1)

Sol. Scientist have even isolated single cell protoplasts from two different varieties of plants each having a desirable character and after digesting their cell walls have been able to isolate naked protoplasts (surrounded by plasma membrane) that can be fused to get hybrid protoplast, which can be further grown to form a new plant. These hybrids are called somatic hybrids, while the process is called somatic hybridization.

So the correct sequence for the formation of somatic hybrids is D, A, B, C, E.

113. Match List-I with List-II :

	List-I		List-II
A.	Conjunctive tissue	I.	Specialised cells in the vicinity of guard cells
B.	Casparian strips	II.	Endodermal cells rich in starch
C.	Subsidiary cells	III.	Tissue between xylem and phloem
D.	Starch sheath	IV.	Endodermal cells with suberin deposition

Choose the **correct** answer from the options given below :

- (1) A-IV, B-III, C-I, D-II
- (2) A-III, B-IV, C-II, D-I
- (3) A-III, B-IV, C-I, D-II
- (4) A-IV, B-III, C-II, D-I

Answer (3)

Sol. (A) Conjunctive tissue is the tissue between xylem and phloem.

(B) Casparian strips are found in endodermal cells, they are suberin depositions in the cell wall.

(C) Subsidiary cells are specialised cells in the vicinity of guard cells.

(D) Starch sheath is another name for endodermal cells rich in starch.

114. Which one of the following is **not** a characteristic of plant cells in the phase of elongation?

- (1) New cell wall deposition
- (2) Cell enlargement
- (3) Increased vacuolation
- (4) Large conspicuous nuclei

Answer (4)

Sol. Phase of elongation is characterised by new cell wall deposition, increased vacuolation and enlargement of cell. Presence of large conspicuous nuclei is a feature of cells in the meristematic phase.

115. Match List-I with List-II

	List-I (Growth Regulator)		List-II (Function/Effect)
A.	2,4-D	I.	Brewing industry
B.	GA ₃	II.	Stimulation of stomatal closure
C.	Kinetin	III.	Herbicide
D.	ABA	IV.	Nutrient mobilisation

Choose the **correct** answer from the options given below :

- (1) A-III, B-I, C-IV, D-II
- (2) A-IV, B-III, C-II, D-I
- (3) A-I, B-IV, C-III, D-II
- (4) A-I, B-II, C-IV, D-III

Answer (1)

	List-I (Growth Regulator)		List-II (Function/Effect)
A.	2,4-D (Auxin)	III.	Herbicide
B.	GA ₃ (Gibberellic Acid)	I.	Brewing industry
C.	Kinetin (Cytokinin)	IV.	Nutrient mobilisation
D.	ABA (Abscisic Acid)	II.	Stimulation of stomatal closure

116. The enzyme required for carboxylation in the Calvin cycle is

- (1) Hexokinase
- (2) PEP carboxylase
- (3) RuBP carboxylase - oxygenase
- (4) Carboxypeptidase

Answer (3)

Sol. RuBisCO (RuBP carboxylase -oxygenase) is the enzyme required for carboxylation in the calvin cycle.

117. How many ATP and NADPH molecules are required to make one molecule of glucose through the Calvin pathway?

- (1) 18 ATP and 12 NADPH
- (2) 12 ATP and 18 NADPH
- (3) 24 ATP and 18 NADPH
- (4) 6 ATP and 12 NADPH

Answer (1)

Sol. Each turn of Calvin pathway utilizes 3ATP and NADPH+H⁺ molecules for fixation of 1 CO₂ molecule.

So for 1 Glucose 6 turns are required, hence 18 ATP and 12 NADPH+H⁺ are required for glucose synthesis.

118. Which of the following floral formula is the correct floral formula of Solanaceae family?

- (1) $\oplus \overset{\text{♂}}{\underset{\text{♀}}{\text{K}}}_{(5)} \overset{\text{♂}}{\underset{\text{♀}}{\text{C}}}_{(5)} \overset{\text{♂}}{\underset{\text{♀}}{\text{A}}}_5 \underline{\text{G}}_{(2)}$
- (2) $\oplus \overset{\text{♂}}{\underset{\text{♀}}{\text{K}}}_{(5)} \overset{\text{♂}}{\underset{\text{♀}}{\text{C}}}_{(5)} \overset{\text{♂}}{\underset{\text{♀}}{\text{A}}}_5 \underline{\text{G}}_{(2)}$
- (3) $\oplus \overset{\text{♂}}{\underset{\text{♀}}{\text{K}}}_5 \overset{\text{♂}}{\underset{\text{♀}}{\text{C}}}_5 \overset{\text{♂}}{\underset{\text{♀}}{\text{A}}}_5 \underline{\text{G}}_{(2)}$
- (4) $\oplus \overset{\text{♂}}{\underset{\text{♀}}{\text{K}}}_5 \overset{\text{♂}}{\underset{\text{♀}}{\text{C}}}_{(5)} \overset{\text{♂}}{\underset{\text{♀}}{\text{A}}}_5 \underline{\text{G}}_{(2)}$

Answer (2)

Sol. $\oplus \overset{\text{♂}}{\underset{\text{♀}}{\text{K}}}_{(5)} \overset{\text{♂}}{\underset{\text{♀}}{\text{C}}}_{(5)} \overset{\text{♂}}{\underset{\text{♀}}{\text{A}}}_5 \underline{\text{G}}_{(2)}$

Is the floral formula for Solanaceae.

It shows actinomorphic, bisexual, pentamerous flower with epipetalous condition

Generally in Solanaceae, calyx (K) and Corolla (C) shows fusion in sepals and petals respectively. Hence the floral formula must exhibit gamosepalous and gamopetalous condition.

119. Which of the following is an *in situ* conservation method?

- (1) Sacred Groves
- (2) Wildlife Safari Parks
- (3) Botanical Gardens
- (4) Seed Banks

Answer (1)

Sol. *In-situ* conservation is exemplified by sacred groves. Wildlife Safari parks, Botanical gardens, seed banks are examples of *in-situ* conservation.

120. Which of the following statements are **not** true regarding restriction endonucleases?

- A. They are called molecular scissors.
- B. These are the enzymes responsible for restricting the growth of bacteriophages in *E. coli*.
- C. They cut the DNA only at the centre of the palindromic sites.
- D. They remove nucleotides only from the ends of DNA fragments.
- E. They recognise specific palindromic base-pair sequences.

Choose the answer from the options given below :

- (1) A and B only
- (2) A and E only
- (3) D and E only
- (4) C and D only

Answer (4)

Sol. Statements C and D are incorrect. Restriction endonucleases usually cut the DNA slightly away from the centre of palindrome sites. They cannot remove nucleotides from the ends of the DNA fragment, which is function of restriction exonuclease.

121. In racemose inflorescence, _____.

- (1) The main axis terminates in a flower
- (2) Flowers are solitary
- (3) The growth is limited
- (4) Flowers are borne in an acropetal succession

Answer (4)

Sol. In racemose type of inflorescence, the main axis continues to grow and the flowers are borne laterally in an acropetal succession. On the contrary, in cymose type of inflorescence, the main axis terminates into a flower and hence, is limited in growth.

122. Arrange the following in the correct developmental sequence related to microsporogenesis :
- A. Microspore tetrads
 - B. Sporogenous tissue
 - C. Pollen grains
 - D. Pollen mother cells

Choose the **correct** answer from the options given below :

- (1) D, A, C, B
- (2) B, D, A, C
- (3) B, D, C, A
- (4) A, D, C, B

Answer (2)

Sol. The process of formation of microspores from a pollen mother cell (PMC) through meiosis is called microsporogenesis.

The correct developmental sequence related to microsporogenesis will be –

Sporogenous tissue (B) → Pollen mother cell (D) → Microspore tetrads (A) → Pollen grains (C)

123. Identify the correct statements about biomolecules.

- A. Lipids are generally water soluble.
- B. Proteins are polypeptides.
- C. Polysaccharides are long chains of sugars.
- D. Adenine and guanine are substituted pyrimidines.
- E. Almost all enzymes are proteins.

Choose the **correct** answer from the options given below :

- (1) B, D and E only
- (2) B, C and E only
- (3) A, B and C only
- (4) C, D and E only

Answer (2)

Sol. Statements B, C and E are correct.

Statements A and D are not true.

Lipids are not water soluble. Adenine and guanine are substituted purines.

124. Which of the following statements are true with reference to the sex-determination in honeybees?

- A. An offspring formed from the union of a sperm and an egg, develops as a female (queen or worker).
- B. An unfertilized egg develops as a male by parthenogenesis.
- C. A male has half the number of chromosomes than that of a female.
- D. Males produce sperms by meiosis.
- E. Honeybees have a haplodiploid sex-determination system.

Choose the **correct** answer from the options given below :

- (1) A, B, C and E only
- (2) B, C, D and E only
- (3) A, B, C and D only
- (4) A, B, D and E only

Answer (1)

Sol. In case of honeybees, males have half the number of chromosomes than that of females. The females are diploid, having 32 chromosomes and males are haploid, i.e., having 16 chromosomes. This is called as haplodiploid sex-determination system and has special characteristic features, such as, the males produce sperms by mitosis.

125. Heterophyllous development in response to environment is an example of which of the following phenomena?

- (1) Redifferentiation
- (2) Elasticity
- (3) Dedifferentiation
- (4) Plasticity

Answer (4)

Sol. Plants follow different pathways in response to environment or phases of life to form different kinds of structures. This ability is called plasticity, e.g., heterophylly in cotton, coriander and larkspur.

126. Which of the following statements are correct regarding amino acids?

- A. They are substituted methanes.
- B. Serine is an aromatic amino acid.
- C. Valine is a neutral amino acid.
- D. Lysine is an acidic amino acid.

Choose the **correct** answer from the options given below:

- (1) C and D only
- (2) B and C only
- (3) A and C only
- (4) A and B only

Answer (3)

Sol. Statements A and C are correct while statements B and D are incorrect. Serine is an alcoholic amino acid and lysine is a basic amino acid.

127. "The Evil Quartet" of biodiversity loss includes which of the following?

- (1) Over-exploitation; Alien species invasions; Air pollution; Co-extinctions
- (2) Habitat loss and fragmentation; Air pollution; Water pollution; Co-extinctions
- (3) Habitat loss and fragmentation; over-exploitation; Alien species invasions; Co-extinctions
- (4) Over-exploitation; Alien species invasions; Soil pollution; Co-extinctions

Answer (3)

Sol. 'The Evil Quartet' is the Sobriquet used to describe the four major causes of biodiversity loss which includes Habitat loss and fragmentation, over-exploitation; Alien species invasions and Co-extinctions.

128. Match List-I with List-II:

	List-I (Process)		List-II (Location)
A.	Glycolysis	I.	Inner mitochondrial membrane
B.	ETS	II.	Mitochondrial matrix
C.	Accumulation of protons	III.	Cytoplasm
D.	Krebs' cycle	IV.	Intermembrane space

Choose the **correct** answer from the options given below:

- (1) A-IV, B-II, C-I, D-III
- (2) A-II, B-III, C-IV, D-I
- (3) A-III, B-I, C-IV, D-II
- (4) A-I, B-IV, C-III, D-II

Answer (3)

Sol. The site of glycolysis is the cytoplasm in all living organisms. Electron transport system is localized in inner mitochondrial membrane. Accumulation of protons occur in intermembrane space and Kreb's Cycle takes place in mitochondrial matrix.

129. Which one of the following is a triploid cell?

- (1) Synergid
- (2) Central cell
- (3) Zygote
- (4) Primary endosperm cell

Answer (4)

Sol. Synergid is haploid, Zygote is diploid, Central cell initially contains two polar nuclei which fuse just before fertilization to form a secondary nucleus ($2n$).

Primary endosperm cell (PEC) is triploid.

130. Which one of the following types of pollination brings genetically different types of pollen grains to the stigma?

- (1) Autogamy
- (2) Xenogamy
- (3) Geitonogamy
- (4) Cleistogamy

Answer (2)

Sol. Transfer of pollen grains from anther to stigma of a different plant is known as Xenogamy. This is the only type of pollination which brings genetically different types of pollen grains to stigma. Cleistogamy flowers are invariably autogamous.

- Sol.**
- Trypsin is a proteolytic enzyme.
 - Morphine is a secondary metabolite that belongs to the category of alkaloid.
 - Concanavalin A is a lectin.
 - Collagen acts as an intercellular ground substance.

134. Which of the following statements are correct with respect to DNA separation, isolation and visualization?

- A. The cutting of DNA is done by molecular scissors.
- B. The DNA fragments separate according to their size in an agarose gel, upon electrophoresis.
- C. The separated DNA fragments can be seen without staining when exposed to UV light.
- D. The separated DNA fragments, when stained with ethidium bromide, can be seen in visible light.

Choose the **correct** answer from the options given below :

- (1) B and D only
- (2) A and B only
- (3) B and C only
- (4) A and D only

Answer (2)

- Sol.**
- The cutting of DNA is possible by the use of restriction enzymes that results in the fragments of DNA. These fragments of DNA can be separated by a technique known as gel electrophoresis.
 - The DNA fragments separate (resolve) according to their size through sieving effect provided by the agarose gel.
 - The separated DNA fragments can be visualised only after staining the DNA with a compound known as ethidium bromide followed by exposure to UV radiation.

135. Which one of the following disorders is caused by the substitution of Glutamic acid (Glu) by Valine (Val) at the sixth position of the beta globin chain of the haemoglobin molecule?

- (1) Thalassemia
- (2) Sickle-cell anaemia
- (3) Phenylketonuria
- (4) Haemophilia

Answer (2)

- Sol.** Sickle cell anaemia is an autosome linked recessive trait that can be transmitted from parents to offsprings when both partners are carrier for the gene. The defect is caused by the substitution of Glutamic acid (Glu) by Valine (Val) at sixth position of beta globin chain of haemoglobin molecule.

138. In humans, respiration occurs in the following steps. Arrange these steps in the correct order.
- Diffusion of O_2 and CO_2 between blood and tissues
 - Diffusion of O_2 and CO_2 across alveolar membrane
 - Pulmonary ventilation by which atmospheric air is drawn in and CO_2 rich alveolar air is released out
 - Cellular respiration
 - Transport of gases by the blood

Choose the **correct** answer from the options given below

- A, B, C, D, E
- E, A, C, D, B
- C, B, E, A, D
- C, A, B, E, D

Answer (3)

Sol. Respiration involves the following steps:

- Breathing or pulmonary ventilation by which atmospheric air is drawn in and CO_2 rich alveolar air is released out.
- Diffusion of gases across alveolar membrane.
- Transport of gases by the blood
- Diffusion of O_2 and CO_2 between blood and tissues
- Utilisation of O_2 by the cells for catabolic reactions and resultant release of CO_2

139. The following are the stages of life cycle of *Plasmodium*. Arrange the stages in the proper order.
- The parasites reproduce asexually in RBCs, bursting the cells.
 - The parasites reproduce asexually in liver cells, bursting the cells and releasing into blood.
 - Gametocytes develop in RBCs.
 - Sporozoites reach the liver through the blood.
 - Female mosquito injects sporozoites into humans during bite.

Choose the **correct** answer from the options given below:

- E, D, B, A, C
- A, B, C, D, E
- C, A, B, D, E
- E, C, D, B, A

Answer (1)

Sol. *Plasmodium* enters the human body as sporozoites through the bite of an infected female *Anopheles* mosquito. The parasites initially multiply asexually within the liver cells and then attack the RBCs resulting in their rupture.

- Sexual stages (gametocytes) develop in red blood cells.
- When a female *Anopheles* mosquito bites an infected person, these parasites enter the mosquito's body and undergo further development.

140. Insertion of a foreign DNA at BamHI site in an *E.coli* cloning vector pBR322 results in the loss of antibiotic resistance towards:

- Ampicillin and tetracycline
- Ampicillin
- Tetracycline
- Gentamycin

Answer (3)

Sol. If one ligate a foreign DNA at the BamHI site of tetracycline resistance gene in the vector pBR322, the recombinant plasmid will lose tetracycline resistance due to insertion of foreign DNA.

141. The following reaction depicts the activity of a particular class of enzymes :

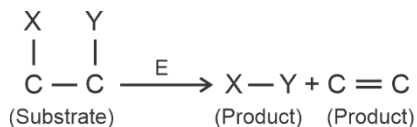

Identify the enzymes class 'E' from the following options :

- (1) Transferases
- (2) Isomerases
- (3) Lyases
- (4) Ligases

Answer (3)

Sol. Lyases are the enzymes that catalyse removal of groups from substrates by mechanisms other than hydrolysis leaving double bonds.

- Transferases are the enzymes that catalyse a transfer of a group between a pair of substrates.
- Isomerases catalyse inter-conversion of optical, geometric or positional isomers.
- Ligases catalyse the linking together of 2 compounds.

142. The specific receptors for neurotransmitters in a synapse are present on _____.

- (1) Schwann cell
- (2) Pre-synaptic membrane
- (3) Myelin sheath
- (4) Post-synaptic membrane

Answer (4)

Sol. The specific receptors for neurotransmitters in a synapse are present on post-synaptic membrane.

143. What is the probability of having children with 'O' blood group, where both mother and father are heterozygous for 'A' and 'B' blood group, respectively?

- (1) 25%
- (2) 0%
- (3) 75%
- (4) 50%

Answer (1)

Sol.

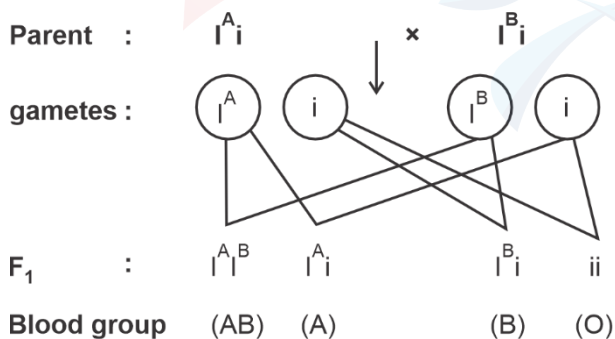

∴ Out of four children, one is with blood group 'O'.

∴ The probability of having children with 'O' blood group will be 25%

144. Match List-I with List-II.

	List-I (Respiratory Volume)		List-II (Capacity in mL)
A.	ERV (Expiratory Reserve Volume)	I.	2500 – 3000 mL
B.	RV (Residual Volume)	II.	500 mL
C.	IRV (Inspiratory Reserve Volume)	III.	1000 – 1100 mL
D.	TV (Tidal Volume)	IV.	1100 – 1200 mL

Choose the **correct** answer from the options given below :

- (1) A-III, B-IV, C-I, D-II
- (2) A-III, B-I, C-IV, D-II
- (3) A-I, B-III, C-II, D-IV
- (4) A-I, B-II, C-III, D-IV

Answer (1)

Sol. ERV (Expiratory Reserve Volume) – 1000 – 1100 mL

RV (Residual Volume) – 1100–1200 mL

IRV (Inspiratory Reserve Volume) – 2500–3000 mL

TV (Tidal Volume) – 500 mL

145. Which of the following is **not** an example of convergent evolution?

- (1) Flippers of penguins and dolphins
- (2) Eyes of octopuses and mammals
- (3) Fore limbs of whales and bats
- (4) Wings of butterflies and birds

Answer (3)

Sol. Fore limbs of whales and bats are examples of divergent evolution that show homology.

146. Male frogs can be distinguished from female frogs due to the presence of

- A. Bulging eyes
- B. Vocal sacs
- C. Webbed digits in feet
- D. Copulatory pad on first digit of fore limbs
- E. Olive green-coloured skin with dark irregular spots

Choose the correct answer from the options given below

- (1) B and C only
- (2) C and E only
- (3) A and B only
- (4) B and D only

Answer (4)

Sol. Male frogs can be distinguished from female frogs due to the presence of vocal sacs and copulatory pad on first digit of fore limbs.

Bulging eyes, webbed digit in feet and olive green-coloured skin with dark irregular spots are common in both male and female frogs.

147. A group of researchers procured some fish like animals and upon investigation the following characters were observed:

- A. Endoskeleton was made of cartilage.
- B. Ectoparasitic; as they were found attached on fish skin with their circular sucking mouth.
- C. Paired fins and scales were absent, but 7 pairs of gill slits were present.

Which of the following species of animals did they consider to fit best with these characters?

- (1) *Scoliodon sp.*
- (2) *Petromyzon sp.*
- (3) *Exocoetus sp.*
- (4) *Branchiostoma sp.*

Answer (2)

Sol. *Petromyzon sp.* have cartilaginous endoskeleton. They have circular sucking mouth. They are ectoparasites on some fishes. Their body is devoid of scales and paired fins. They have 7 pairs (6-15 pairs) of gill slits.

Scoliodon and *Exocoetus* are not parasites.

148. Match List I with List II with respect to chronology of evolution of life forms

	List-I		List-II
A.	About 65 mya	(I)	Jawless fish probably evolved
B.	About 500 mya	(II)	The dinosaurs suddenly disappeared from the earth
C.	About 350 mya	(III)	Seaweeds and few plants probably existed
D.	About 320 mya	(IV)	Invertebrates were formed and became active

Choose the correct answer from the options given below:

- (1) A(III), B(IV), C(I), D(II)
- (2) A(I), B(II), C(III), D(IV)
- (3) A(II), B(IV), C(III), D(I)
- (4) A(II), B(IV), C(I), D(III)

Answer (4)

Sol.

About 65 mya – The dinosaurs suddenly disappeared from the earth.

About 500 mya – Invertebrates were formed and became active.

About 350 mya – Jawless fish probably evolved.

About 320 mya – Seaweeds and few plants probably existed.

Sol. Nicotine is present in tobacco and it activates adrenal medulla to release catecholamines into blood circulation, so (A) → II
 Morphine acts as an effective sedative and painkiller. It is an opioid, so (B) → III
 Heroin acts as a depressant and slows down body function, so (C) → IV
 Cocaine acts as a stimulant and causes a sense of euphoria and increased energy, so (D) → I
 Thus, (A) → II, (B) → III, (C) → IV, (D) → I

152. The human protein named α -1-antitrypsin, obtained from transgenic animals, is used for the treatment of _____.
- | | |
|--------------------------|-------------------------|
| (1) Emphysema | (2) Alzheimer's disease |
| (3) Rheumatoid arthritis | (4) Cystic fibrosis |

Answer (1)

Sol. The human protein named α -1-antitrypsin, obtained from transgenic animals, is used for the treatment of emphysema.

Transgenic models exist for the study of other diseases, such as Alzheimer's disease, rheumatoid arthritis and cystic fibrosis.

153. Select the set of fishes which belong to the class Osteichthyes:
- | | |
|--|---|
| (1) Devil fish, Cuttlefish and Hagfish | (2) Saw fish, Fighting fish and Dog fish |
| (3) Starfish, Hagfish and Cuttlefish | (4) Flying fish, Angel fish and Fighting fish |

Answer (4)

Sol. Flying fish (*Exocoetus*) is a marine bony fish. Angel fish (*Pterophyllum*) and fighting fish (*Betta*) are aquarium bony fishes.

Option (1) is incorrect as:-

Devil fish (*Octopus*) and cuttlefish (*Sepia*) are molluscs.

Hag fish (*Myxine*) is a cyclostome.

Option (2) is incorrect as:-

Saw fish (*Pristis*) and dog fish (*Scoliodon*) are cartilaginous fishes.

Option (3) is incorrect as:-

Star fish (*Asterias*) is an echinoderm.

154. Select the **incorrect** statements from the following:
- Digestive system in Platyhelminthes is incomplete.
 - Bilateral symmetry is a characteristic feature of adult Echinoderms.
 - Pseudocoelom is possessed by Aschelminthes.
 - Notochord is persistent throughout life in the class Chondrichthyes.
 - Members of class Reptilia maintain a constant body temperature.

Choose the answer from the options given below:

- | | |
|------------------|------------------|
| (1) A and C only | (2) B and E only |
| (3) C and D only | (4) B and D only |

Answer (2)

Sol. (A) → correct → Platyhelminthes have an incomplete digestive system.

(B) → incorrect → Bilateral symmetry is a characteristic feature of larvae of echinoderms. In adult echinoderms, radial symmetry is seen.

(C) → correct → Aschelminthes are characterised by the presence of pseudocoelom.

(D) → correct → Notochord is persistent throughout life in the Chondrichthyes.

(E) → incorrect → Reptiles are cold-blooded organisms and thus, they cannot maintain a constant body temperature.

Warm-blooded organisms like birds and mammals can maintain a constant body temperature.

Thus, as the incorrect statements are indicated by (B) and (E) only

155. Non-membrane bound cell organelles found in both prokaryotic and eukaryotic cells are _____.

- (1) Ribosomes (2) Lysosomes
(3) Centrosomes (4) Mitochondria

Answer (1)

Sol. Ribosome is a non-membrane bound cell organelle, found in both prokaryotic and eukaryotic cells.

156. Which of the following equations depicts Verhulst-Pearl logistic population growth?

- (1) $\frac{dN}{dt} = rN \left(\frac{K + N}{K} \right)$ (2) $\frac{dN}{dt} = rN \left(\frac{K - N}{K} \right)$
(3) $\frac{dN}{dt} = rN \left(\frac{K - N}{N} \right)$ (4) $\frac{dN}{dt} = rN \left(\frac{K}{K - N} \right)$

Answer (2)

Sol. Verhulst-Pearl logistic population growth is depicted by the equation $\frac{dN}{dt} = rN \left(\frac{K - N}{K} \right)$

Where

- K = Carrying capacity
- r = Intrinsic rate of natural increase
- N = Population density at time 't'

157. Select the **incorrect** statement with reference to Rh grouping.

- A. Erythroblastosis foetalis is a condition observed having foetus with Rh^{-ve} blood and mother with Rh^{+ve} blood.
B. Rh antigen is observed on RBCs in the majority of human beings.
C. Before blood transfusion, Rh group should also be matched.
D. Rh incompatibility is observed when a pregnant mother is Rh^{-ve} and the foetus is Rh^{+ve}.
E. Erythroblastosis foetalis can be avoided by administering anti-Rh antibodies to the mother immediately after the delivery of the second child.

Choose the answer from the options given below :

- (1) C and D only (2) A and B only
(3) A and E only (4) B and C only

Answer (3)

Sol.

- (A) Incorrect → A special case of Rh incompatibility has been observed between the Rh^{-ve} blood of a pregnant mother with Rh^{+ve} blood of the foetus.
(B) Correct → Rh antigen is observed on the surface of RBCs of majority (nearly 80 percent) of humans.
(C) Correct → Before blood transfusion, Rh group should also be matched to avoid severe problems of destruction of RBCs.
(D) Correct → Rh incompatibility (Erythroblastosis foetalis) is observed when a pregnant mother is Rh^{-ve} and the foetus is Rh^{+ve}.
(E) Incorrect → Erythroblastosis foetalis can be avoided by administering anti-Rh antibodies to the mother immediately after the delivery of the first child.

Thus, the incorrect statements are (A) and (E).

158. Match List I with List II:

	List I (Bioactive molecules)		List II (Importance)
A.	Streptokinase	I.	Immunosuppressive agent
B.	Statins	II.	Removal of clots from the blood vessels
C.	Lipases	III.	Blood cholesterol-lowering agent
D.	Cyclosporin A	IV.	Detergent formulations

Choose the correct answer from the options given below:

(1) A-II, B-III, C-I, D-IV

(2) A-IV, B-III, C-II, D-I

(3) A-III, B-II, C-IV, D-I

(4) A-II, B-III, C-IV, D-I

Answer (4)

Sol. Streptokinase → Used as 'clot buster' for removing clots from the blood vessels

Statins → Blood cholesterol lowering agent, produced by *Monascus purpureus*

Lipases → Used in detergent formulation

Cyclosporin A → Used as immunosuppressive agent in organ transplant patients and produced by *Trichoderma polysporum*

159. Match List I with List II:

	List I		List II
A.	Molluscs	I.	Pulmonary respiration only
B.	Reptiles	II.	Branchial respiration
C.	Adult amphibians	III.	Cellular respiration
D.	Amoeba	IV.	Pulmonary and cutaneous respiration

Choose the correct answer from the options given below:

(1) A-II, B-I, C-IV, D-III

(2) A-I, B-II, C-IV, D-III

(3) A-II, B-I, C-III, D-IV

(4) A-III, B-II, C-I, D-IV

Answer (1)

Sol. (A) Molluscs → (II) Perform branchial respiration by using feather-like gills

(B) Reptiles → (I) Perform pulmonary respiration only via lungs

(C) Adult amphibians → (IV) Perform pulmonary and cutaneous respiration via lungs and moist skin, respectively

(D) Amoeba → (III) Performs cellular respiration to generate ATP for survival

Thus, (A) – II, (B) – I, (C) – IV, (D) – III

160. The sixth mutant codon of beta globin gene causing polymerization of Haemoglobin and change in RBC shape is _____.
- (1) GUG (2) AUG
(3) GAG (4) CAG

Answer (1)

Sol. Sickle cell anaemia is an autosomal recessive disorder which is caused by the substitution of Glutamic acid by Valine, at the sixth position of the beta globin chain of the haemoglobin molecule. The substitution of amino acid in the globin protein results due to the single base substitution from GAG to GUG. Hence, GUG is responsible for the change in the shape of RBC.

161. Choose the correct statements regarding muscle contraction.
- A. A motor neuron carries a signal sent by the Central Nervous System (CNS) to the sarcolemma of the muscle fibre.
B. The neural signal generates an action potential which causes the release of Ca^{++} into sarcoplasm.
C. Increase in Ca^{++} inactivates the actin for breaking cross bridges.
D. Actin binds to the myosin head to form a cross bridge.
E. Shortening of sarcomere takes place, by pulling actin filaments towards the centre of 'A' band.

Choose the **correct** answer from the options given below :

- (1) C and D only
(2) A and B only
(3) C and E only
(4) A, B, D and E only

Answer (4)

Sol. Statements A, B, D and E are correct while statement C is incorrect.

A neural signal reaching neuromuscular junction releases a neurotransmitter (Acetylcholine) which generates an action potential in the sarcolemma. This spreads through muscle fibre and causes the release of Ca^{++} into the sarcoplasm. This Ca^{++} binds to the subunit of troponin on actin filaments and thereby remove the masking of active site for myosin on actin and hence facilitates the formation of cross bridge.

162. Which of the following statements are correct with reference to human endoskeleton?
- A. Human skull is monocondylic.
B. The joint between any two adjoining vertebrae is a cartilaginous joint.
C. In human beings, the number of cervical vertebrae is seven.
D. All ribs except the last 2 pairs are bicephalic.
E. The occipital bone of skull is articulated with atlas vertebra.

Choose the **correct** answer from the options given below:

- (1) B and E only (2) B, C and E only
(3) C, D and E only (4) A, B and D only

Answer (2)

Sol. (A) Incorrect : Human skull is dicondylic. The skull region articulates with the superior region of the vertebral column (Atlas) with the help of two occipital condyles.

(B) Correct : The joint present between the adjacent vertebrae of vertebral column is cartilaginous joints.

(C) Correct : There are 7 cervical vertebrae in human beings.

(D) Incorrect : All ribs of humans are bicephalic, *i.e.*, they have two articulation surfaces on their dorsal end.

(E) Correct : The occipital bone of the skull articulates with the atlas vertebra *via* occipital condyles, forming the atlanto-occipital joint.

163. Spermatogonia undergo a series of cell divisions statements to produce sperms. Select the correct from the following :

- A. Spermatogonia always undergo meiotic cell division.
- B. Primary spermatocytes divide mitotically to produce secondary spermatocytes.
- C. Secondary spermatocytes, through their second meiotic division, produce haploid spermatids.
- D. Spermatids produce spermatozoa through mitosis.
- E. Spermatids transform into spermatozoa by spermiogenesis.

Choose the correct answer from the options given below:

- (1) A and E only
- (2) C and E only
- (3) A, C and E only
- (4) B, C and D only

Answer (2)

Sol. (A) Incorrect : Spermatogonia undergo mitotic differentiation.

(B) Incorrect : Primary spermatocytes undergo 1st meiotic division to form secondary spermatocytes.

(C) Correct : Secondary spermatocytes undergo 2nd meiotic division to form the haploid spermatids.

(D) Incorrect : Spermatids form spermatozoa through a differentiation process called spermiogenesis.

(E) Correct : Spermatids produce spermatozoa *via* spermiogenesis.

Thus, the correct statements are (C) and (E) only.

164. The JGA (Juxta Glomerular Apparatus) is a special sensitive region formed by cellular modifications in _____ related to the same nephron.

- (1) Distal convoluted tubule and efferent renal arteriole
- (2) Proximal convoluted tubule and efferent renal arteriole
- (3) Proximal convoluted tubule and afferent renal arteriole
- (4) Distal convoluted tubule and afferent renal arteriole

Answer (4)

Sol. JGA is a special sensitive region formed by cellular modifications in the distal convoluted tubule and the afferent arteriole at the location of their contact.

165. Which one of the following is an appropriate example of sexual deceit?

- (1) Female wasp and fig
- (2) Ophrys and bumblebee
- (3) Sea anemone and clown fish
- (4) Cuckoo and crow

Answer (2)

Sol. Female wasp and fig – Mutualism

Ophrys and bumblebee – Sexual deceit

Sea anemone and clown fish – Commensalism

Cuckoo and crow – Brood Parasitism

166. Choose the correct statements regarding frog's anatomy:

- A. Hepatic portal system is the special venous connection between liver and intestine.
- B. There are twelve pairs of cranial nerves arising from the brain.
- C. The ureters and oviducts open separately into the cloaca in female frogs.
- D. Hind-brain consists of cerebellum, medulla oblongata and optic lobes.
- E. Sinus venosus joins the right atrium of heart.

Choose the **correct** answer from the options given below:

- (1) A, B and C only
- (2) B and D only
- (3) B and C only
- (4) A, C and E only

Answer (4)

Sol. In grasshopper sex determination is XX – XO type, in which, males have only one X-chromosome besides the autosome (XO), whereas females have a pair of X-chromosome, besides autosomes (XX). Therefore, the individual with 23 chromosomes is a male grasshopper and the one with 24 chromosomes is a female grasshopper.

169. In which animal do haploid cells divide mitotically to produce gametes?

- (1) Male honeybees
- (2) Male earthworms
- (3) Male frogs
- (4) Male grasshoppers

Answer (1)

Sol. The male honeybee is haploid and females are diploid. The gamete formation in female honey bee is by meiosis, whereas male honeybee form gametes by mitosis. Thus haploid cell undergoes mitosis in male honeybees.

170. Arrange the following cell layers/structures around the female gamete, from outer to inner side :

- A. Zona pellucida
- B. Perivitelline space
- C. Corona radiata
- D. Plasma membrane of ovum

Choose the **correct** answer from the options given below :

- (1) D, B, A, C
- (2) C, A, D, B
- (3) C, A, B, D
- (4) A, C, B, D

Answer (3)

Sol. The cell layer/structure around the female gamete from outer to inner side is :

Corona radiata → zona pellucida → perivitelline space → plasma membrane of ovum.

So the correct answer is C, A, B, D.

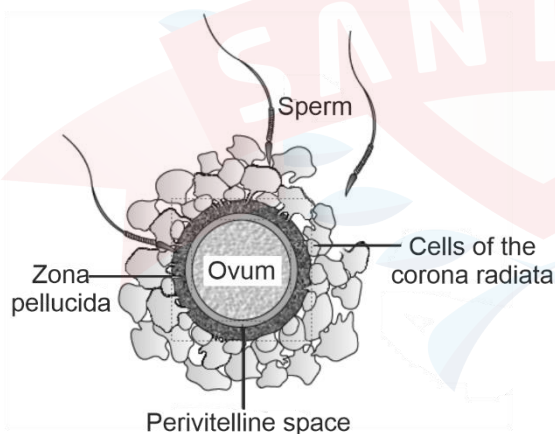

171. What is the reason behind production of large holes in 'Swiss Cheese'?

- (1) The production of large amount of CO₂ by *Propionibacterium sharmanii*
- (2) The production of large amount of CO₂ by *Clostridium butylicum*
- (3) The production of large amount of CO₂ and H₂ by lactic acid bacteria called *Lactobacillus*
- (4) The production of large amount of CO₂ and H₂ by *Trichoderma polysporum*

Answer (1)

Sol. The large holes in swiss cheese are due to production of large amount of CO₂ by the bacterium *Propionibacterium sharmanii*.

- *Clostridium butylicum* is commercially utilised for butyric acid production.
- Curd is formed by *Lactobacillus*.

172. The toxin proteins isolated from *Bacillus thuringiensis*, coded by which of the following genes would control cotton bollworms and corn borer, respectively?

- (1) *cryIAc* and *cryIAb*
- (2) *cryIAc* and *cryIIAb*
- (3) *cryIIAb* and *cryIAc*
- (4) *cryIAc* and *cryIIIAb*

Answer (1)

Sol. Specific Bt toxin genes were isolated from *Bacillus thuringiensis* and incorporated into the several crop plants such as cotton. The choice of genes depends upon the crop and the targeted pest, as most Bt toxins are insect-group specific. The toxin is coded by a gene named *cry*. The proteins encoded by the genes *cryIAc* and *cryIIAb* control the cotton bollworms, that of *cryIAb* controls corn borer. So, the correct answer is *cryIAc* for cotton bollworms and *cryIAb* for corn borer that is represented in option (1)

173. Ecological pyramids represent the relationship between the organisms at different trophic levels and they are generally inverted for:

- (1) Pyramid of number in grassland
- (2) Pyramid of energy in pond ecosystem
- (3) Pyramid of biomass in grassland
- (4) Pyramid of biomass in sea

Answer (4)

Sol. • Pyramid of number in grassland ecosystem is upright

- Pyramid of energy in pond ecosystem is upright
- Pyramid of biomass in grassland is upright
- Pyramid of biomass in sea is inverted

174. Choose the correct statement regarding GIFT to overcome infertility.

- (1) Ova collected from a female donor are transferred to the uterus of an infertile female.
- (2) Early embryos with up to 8 blastomeres are transferred to the uterus of an infertile female.
- (3) Early embryos with up to 8 blastomeres are transferred into the fallopian tube of an infertile female.
- (4) It is the transfer of an ovum collected from a donor into the fallopian tube of another female who cannot produce ovum but can provide suitable environment for fertilization and development.

Answer (4)

Sol. GIFT is an *in-vivo* technique used to assist infertility

GIFT: Gamete Intra Fallopian Transfer technique facilitates the transfer of an ovum collected from a donor into the fallopian tube of another female who cannot produce one, but can provide suitable environment for fertilization and further development.

ZIFT : Zygote Intra Fallopian Transfer is an *in-vitro* technique in which zygote or early embryo upto 8 blastomeres is transferred in fallopian tube.

175. Choose the correct statements regarding cell organelles and their inclusions.
- The endomembrane system includes Golgi complex, endoplasmic reticulum and mitochondria.
 - Rough endoplasmic reticulum bears ribosomes on its surface.
 - Both mitochondria and plastids have circular DNA.
 - A network of microtubules, microfilaments and intermediate filaments present in the cytoplasm is called cytoskeleton.
 - Mitochondrion is a single membrane-bound structure.

Choose the **correct** answer from the options given below :

- A and B only
- A, B and C only
- C, D and E only
- B, C and D only

Answer (4)

Sol. The endomembrane system does not include mitochondria. Mitochondria is a double membrane bound cell organelle.

176. Select the correct statements regarding cell membrane in eukaryotic cell.
- Membrane of human RBCs has approximately 52% protein.
 - Major phospholipids are arranged in a bilayer.
 - Extensions of the plasma membrane into the cell form mesosomes.
 - Tails towards the inner part of lipids are hydrophobic and thus protected from aqueous medium.
 - Glycocalyx is present on the outer surface of the plasma membrane.

Choose the **correct** answer from the options given below:

- C, D and E only
- B, C and E only
- A, B and D only
- A, C and E only

Answer (3)

Sol.

- In prokaryotes, extensions of plasma membrane into the cell form mesosomes. Eukaryotes lack such structure.
- Glycocalyx is present on the outer surface of the plasma membrane in prokaryotes. Eukaryotes do not have glycocalyx.

Hence, only statement A, B and D are correct.

177. Match List I with List II related to muscular/skeletal system:

	List I		List II
A.	Tetany	(I)	Inflammation of joints
B.	Arthritis	(II)	Autoimmune disorder affecting neuromuscular junction
C.	Myasthenia gravis	(III)	Wild contraction in muscle due to low Ca^{++} in body fluid
D	Muscular dystrophy	(IV)	Progressive degeneration of skeletal muscle

Choose the **correct** answer from the options given below:

- A-III, B-I, C-II, D-IV
- A-I, B-II, C-III, D-IV
- A-IV, B-III, C-II, D-I
- A-III, B-II, C-I, D-IV

Answer (1)

Sol. • Arthritis is an inflammation of joints.

- Tetany is rapid spasms (wild contractions) in muscle due to low Ca^{++} in body fluids.
- Muscular dystrophy is progressive degeneration of skeletal muscle mostly due to genetic disorder
- Myasthenia gravis is an autoimmune disorder affecting neuromuscular junction leading to fatigue, weakening and paralysis of skeletal muscle.

Hence, A-III, B-I, C-II, D-IV is the correct match.

178. Evolution of human appears parallel to the progressive development of brain and language skills. As such, the evolution of individual species in the sequence of their appearance is:

- (1) *Ramapithecus* → *Homo habilis* → *Homo erectus* → *Neanderthal* → *Homo sapiens*
- (2) *Homo sapiens* → *Ramapithecus* → *Homo habilis* → *Neanderthal* → *Homo erectus*
- (3) *Homo habilis* → *Homo erectus* → *Ramapithecus* → *Neanderthal* → *Homo sapiens*
- (4) *Neanderthal* → *Ramapithecus* → *Homo habilis* → *Homo erectus* → *Homo sapiens*

Answer (1)

Sol. • Evolution of human appears parallel to the progressive development of brain and language skills.

- The correct chronological order in which human evolution took place is :

Ramapithecus → *Australopithecines* → *Homo habilis* → *Homo erectus* → *Neanderthalensis* → *Homo sapiens*

179. The flightless bird with forelimbs modified as paddle-like structures suited for swimming is known as:

- (1) *Struthio*
- (2) *Neophron*
- (3) *Aptenodytes*
- (4) *Psittacula*

Answer (3)

Sol. • *Neophron* is vulture and *Psittacula* is a parrot. Both perform flight.

- *Struthio* is ostrich and *Aptenodytes* is penguin. Both are flightless birds.
- In penguins, forelimbs are modified into flippers (paddle like structure) and are used for swimming. In ostriches, forelimbs are small and used for balance while running, not for swimming.

180. Choose the correct statements regarding population interactions between two species.

- A. In both parasitism and commensalism, only one species benefits and the other species is harmed.
- B. Both species benefit in mutualism.
- C. Both species benefit in commensalism.
- D. In parasitism, only one species benefits and the other species is harmed.
- E. In amensalism, one species is harmed and the other is unaffected.

Choose the **correct** answer from the options given below:

- (1) B and E only
- (2) A and B only
- (3) B, D and E only
- (4) A and D only

Answer (3)

Sol. In parasitism, one species is benefitted and the other is harmed. Whereas, in commensalism one species gets benefitted and the other remains unaffected.

